



# Dual Gate Controller

## 24 Volt Gate Control System DCB-05V2

### Contents

<b>1. Important Safety Instructions</b>	<b>3</b>	<b>11. Remotely Coding Transmitters</b>	<b>13</b>
<b>2. Control Board Layout</b>	<b>4</b>	11.1 Selecting The Function To Be Coded	13
<b>3. Set Up Requirements</b>	<b>5</b>	<b>12. Setting Pedestrian Position</b>	<b>14</b>
3.1 Kit Contents	5	12.1 Setting the Pedestrian Position	14
3.2 Choosing your Set up	5	12.2 Checking Pedestrian Position	14
<b>4. Installation Requirements</b>	<b>5</b>	12.3 Error Displays	14
4.1 Mounting Control Box	5	11.2 Activate Remote Code Set Mode	14
4.2 Installing antenna	5	<b>13. Auto-Close Mode</b>	<b>15</b>
<b>5. Wiring Diagrams - Single Gates</b>	<b>6</b>	13.1 Setting Up Standard Auto-Close	15
5.1 Wiring motors and limit switches	6	13.2 Safety Beam Triggered Auto Close	15
5.2 Diodes 1N4004 or equivalent	6	13.3 Pedestrian Auto-Close	15
<b>6. Wiring Diagrams - Dual Gates</b>	<b>7</b>	13.4 Auto-Close After Obstruction:	15
6.1 Wiring motors and limit switches	7	<b>14. Accessories Installation</b>	<b>16</b>
6.2 Diodes 1N4004 or equivalent	7	14.1 Fitting Solenoid Or Magnetic Locks	16
6.3 Dual NeoSlider Kit	8	14.2 Fitting Courtesy Lights	16
<b>7. Programming the DCB-05V2</b>	<b>9</b>	<b>15. Battery Replacement</b>	<b>16</b>
7.1 Common Programs	9	<b>16. Battery Disposal</b>	<b>17</b>
7.2 Powering up the DCB-05V2	9	<b>17. Specifications</b>	<b>17</b>
<b>8. Setting Limits</b>	<b>10</b>	<b>18. Troubleshooting</b>	<b>18</b>
8.1 Setting Travel Limits	10	<b>19. Appendix</b>	<b>19</b>
8.2 Adjusting Close Limit(s)	10	A - Console Menu Structure	19
8.3 Adjusting Open Limit(s)	10	B - Viewing and Editing Parameters	22
8.4 Automatic Profiling	10	C - Control Board Adjustments	23
8.5 Code A Transmitter For Limit Setting	11	D- Diagnostic Tools	24
8.6 Setting Limits Via Transmitter	11	E - Memory Tools	26
<b>9. Safety Obstruction Force Test</b>	<b>12</b>	F- Transmitter Editing	26
9.1 Testing Close Cycle (Single Swing Gates)	12	G- Transmitter Managment	27
9.2 Testing Open Cycle (Single Swing Gates)	12	H- AMP Travel (2 Wires Setup)	28
9.3 Force Pressure For Close Cycle.	12	I - Time Travel 2 Wire Setup	30
9.4 Force Pressure For Open Cycle.	12		
9.5 Reprofileing Travel	12		
<b>10. Coding Transmitter</b>	<b>13</b>		
10.1 Coding Transmitter Button	13		
10.2 Selecting Function Of The Button	13		
10.3 Returning To Main Screen	13		

Automatic Technology Australia Pty Ltd to the extent that such may be lawfully excluded hereby expressly disclaims all conditions or warranties, statutory or otherwise which may be implied by laws as conditions or warranties of purchase of an Automatic Technology Australia Pty Ltd Garage Door Opener. Automatic Technology Australia Pty Ltd hereby further expressly excludes all or any liability for any injury, damage, cost, expense or claim whatsoever suffered by any person as a result whether directly or indirectly from failure to install the Automatic Technology Australia Pty Ltd Garage Door Opener in accordance with these installation instructions.





# 1. Important Safety Instructions

The safety alert symbols below indicate a personal safety or property damage instruction exists. **READ THESE INSTRUCTIONS CAREFULLY.** This DCB-05V2 Gate Opener is designed and tested to offer safe service provided it is installed and operated in strict accordance with the following safety rules. Failure to comply with the following instructions may result in death, serious personal injury or property damage.



## WARNING!

- The gate may operate unexpectedly, therefore do not allow anything to stay in the path of the gate.
- Do not disengage the gate opener to manual operation with children/persons or any objects including motor vehicles within the gateway.
- Make sure the gate is fully open before driving into or out of the driveway.
- When using auto close mode, a **Photo Electric beam** must be fitted correctly and tested for operation at regular intervals. **Extreme caution** is recommended when using auto close mode. **All safety rules** must be followed.



## ELECTROCUTION!

- Do not immerse in or spray the DCB-05V2 with water .
- **Disconnect the power cord** from mains power before making any repairs or removing covers. Only **experienced** service personnel should remove covers from the gate opener.
- If the power supply cord is damaged, it **must** be replaced by an Automatic Technology service agent or suitably qualified person.
- Connect the gate opener to a properly **earthed** general purpose 240V mains power outlet installed by a qualified electrical contractor.



## BATTERY WARNING!

- This product contains a lithium button/coin cell battery in the transmitters. If a new or used lithium button/coin cell battery is swallowed or enters the body, it can cause severe internal burns and can lead to death in as little as 2 hours. Always completely secure the battery compartment. If the battery compartment does not close securely, stop using the product, remove the battery and keep it away from children. If you think batteries might have been swallowed or placed inside any part of the body, SEEK IMMEDIATE MEDICAL ATTENTION.



## CAUTION:

Entrapment from operating gate

- **DO NOT** operate the gate opener unless the gate is in full view and free from objects such as cars and children/people. Make sure that the gate has finished moving before entering or leaving the driveway.
- Do not allow children to play with gate controls or transmitters.
- In order for the DCB-05V2 to **sense** an object obstructing the gateway, some **force** must be exerted on the object. As a result the object, gate and/or person may suffer **damage** or **injury**.
- Regularly check to make sure that the **Safety Obstruction Force** is working correctly, and is **tested** and set as per **Section 12 of this manual**. Failure to follow these instructions could result in **serious personal injury** and/or property damage. This test must be repeated at regular intervals and the necessary adjustments made as required.
- If using a key switch, keypad or any device that can operate the gate opener, make sure it is in a location where the gateway is visible, but out of the reach of children at a height of at least 1.5m.
- For **ADDITIONAL SAFETY** protection we **STRONGLY** recommend the fitting of a Photo Electric (Safety) Beam. In most countries Safety Beams are mandatory on all gates fitted with automatic openers.
- Ensure the gate(s) is in good working order. Faulty gates must be repaired by a qualified technician prior to DCB-05V2 installation.
- Make sure that the gate is fully closed before leaving the driveway.
- Keep hands and loose clothing clear of gate at all times
- Keep clear of gate during operation as severe lacerations can occur on sharp edges of gate.

Installation

Security

Entanglement in or laceration from moving gate

# 2. Control Board Layout

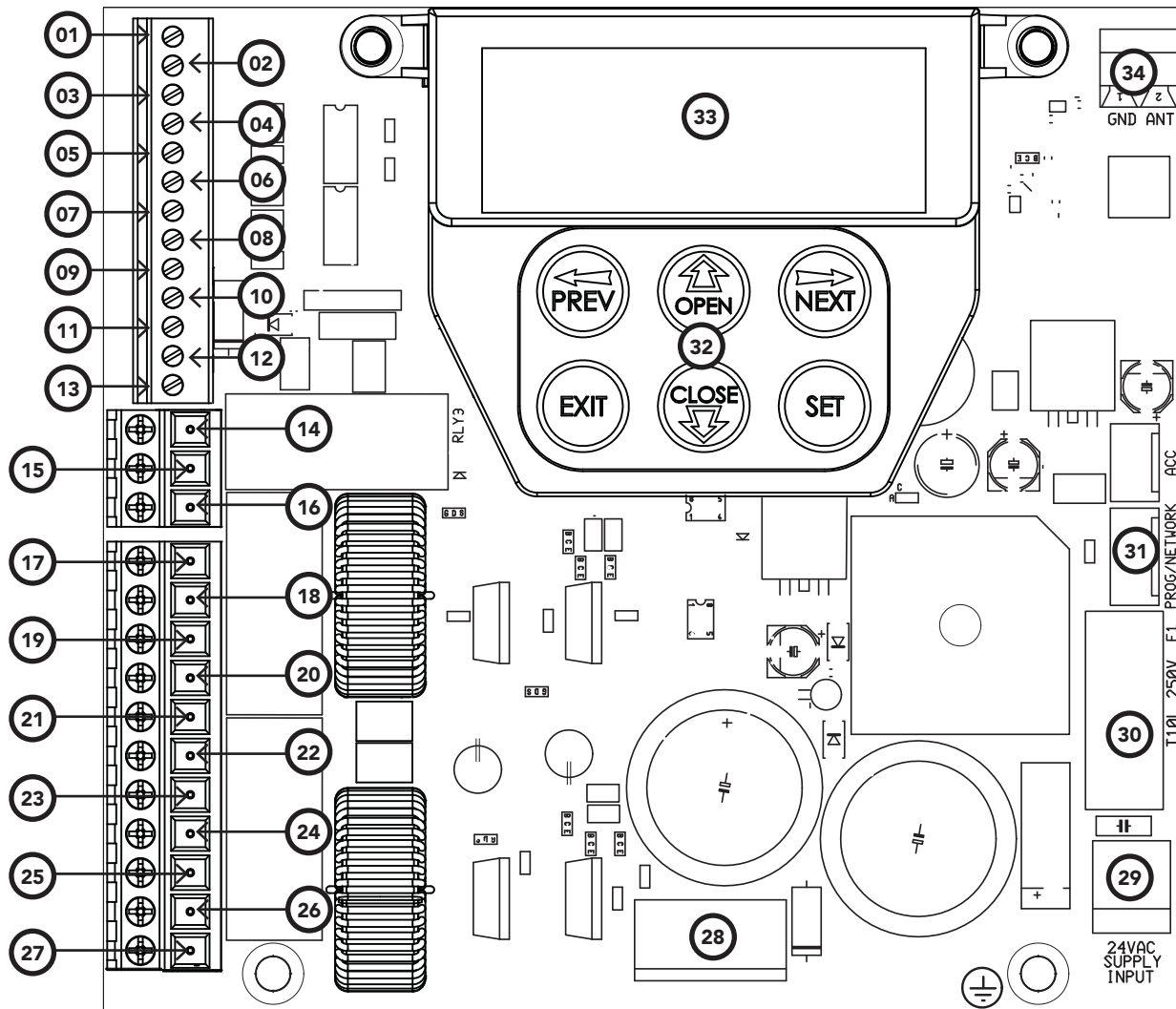

Fig 2.1

- |   |  |  |
|---|--|--|
| 01 SB2 (Safety Beam (2), two, three wire or wireless) | 13 OUT 2 (optional relay module coil drive)  | 25 MOTOR 1 terminal 2                        |
| 02 SB1 (Safety Beam(1), two, three wire or wireless)  | 14 OUT 1 N/C relay contact                   | 26 V PWR for accessories                     |
| 03 0V   | 15 OUT 1 COM relay contact                   | 27 0V  |
| 04 Aux control input                                  | 16 OUT 1 N/O relay contact                   | 28 Standby battery / solar charger connector |
| 05 OPN Programmable N/O or N/C input terminal         | 17 MOTOR 2 terminal 1                        | 29 24VAC power input (from transformer)      |
| 06 STP Programmable N/O or N/C input terminal         | 18 MOTOR 2 terminal 2                        | 30 10 amp fuse                               |
| 07 CLS N/O input terminal                             | 19 MOTOR 2 close limit switch input terminal | 31 Programmer / Network Input                |
| 08 OSC N/O input terminal                             | 20 MOTOR 2 open limit switch input terminal  | 32 Console keypad                            |
| 09 SWP N/O input terminal                             | 21 COM terminal for Terminals 19,20,22 &23.  | 33 Console display (LCD)                     |
| 10 PED N/O input terminal                             | 22 MOTOR 1 close limit switch input terminal | 34 Antenna connector                         |
| 11 0V   | 23 MOTOR 1 open limit switch input terminal  |  |
| 12 V+   | 24 MOTOR 1 terminal                          |  |

# 3. Set Up Requirements

## 3.1 Kit Contents

Item	Description	Qty
1	GATE CONTROL SYSTEM DCB05	1
2	MOUNTING LUGS FOR GEWISS BOX	4
3	SCREW "P" M3.5 X 13	4
4	PTX-6 TRANSMITTER	2
5	RESISTOR 5K6	2

## 3.2 Choosing your Set up

The DCB-05V2 can be set up in various ways and therefore may require additional items. Common Set ups are as follows;

Set Up	Items Required
Automated Set Up	Drive Unit, control system and transmitter
Automated Set Up with Safety Beams	Drive Unit, control system, transmitter and safety beams (optional extra)

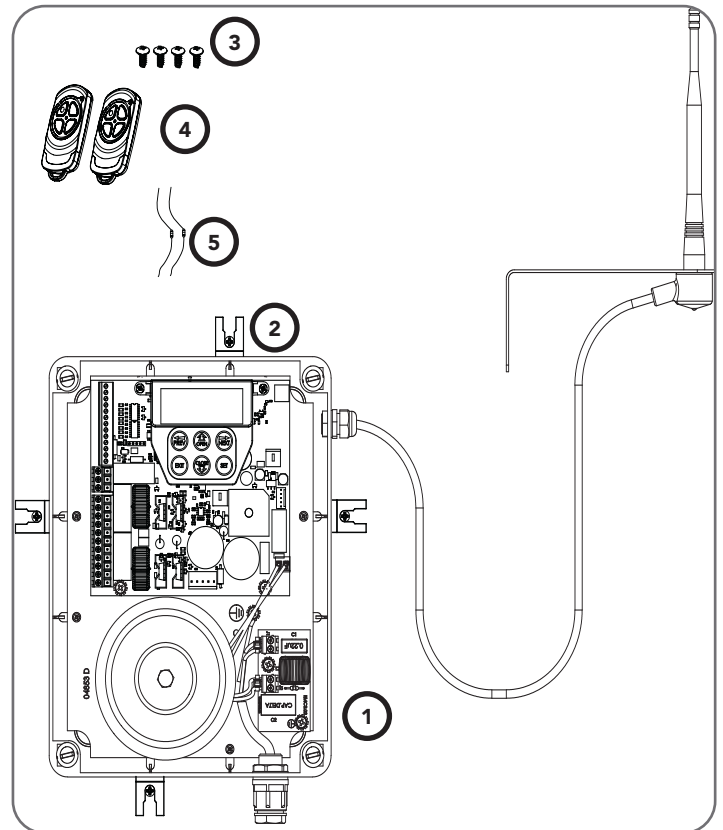

Fig 3.1

# 4. Installation Requirements



## IMPORTANT SAFETY INSTRUCTIONS FOR INSTALLATION

**Warning: Incorrect installation can lead to severe injury. Follow ALL installation instructions.**



**CAUTION: do not use any cables which carry green/yellow wires as this signifies earth, and do not comply with electrical authority regulations.**

### 4.1 Mounting Control Box

- The control box should be mounted near the drive unit using four (4) 6mm screws.
- Drill holes as per (Fig. 4.1). When locating the control box, allow ample space around the unit for easy access and wiring connections.
- Remove cover from control box.
- Dual Gates Only- Determine which leaf you would like to open first and close last. This gate leaf must be connected to Motor 1 (M1) terminals on the control board.
- Connect drive unit(s) to control board. For detailed electrical connection see Section 5.

### 4.2 Installing antenna

Mount the antenna at or above the height of the gate or fence (whichever is higher) for optimal reception. Do not cut the coaxial cable.

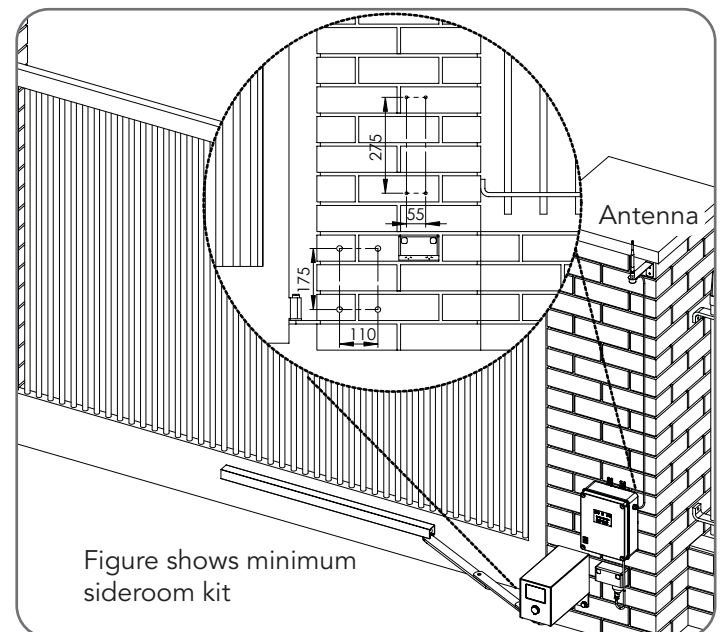

Fig 4.1



# 5. Wiring Diagrams - Single Gates



**CAUTION:** Cables which have a green/yellow coloured insulation are for earthing purposes only. Never use these cables for any other purpose.

## 5.1 Wiring motors and limit switches

DCB-05V2 can be connected to the single gate drive units in one of several ways.

Wiring	Figure #
5 Wire, Single Gate	5.1
3 Wire Single Gate	5.2
2 Wire Single Gate	5.3

The diagrams (**Fig. 5.1 to Fig. 5.3**) show the various wiring methods used for different drive unit types. Select the appropriate method for your drive unit.

**NOTE:** “non-motor current carrying limit-switch” type drive units can be connected using the standard 5 wire connections or a special 3 wire method that uses a single limit switch sense wire and two diodes.

## 5.2 Diodes 1N4004 or equivalent (not included)

The most common function of a diode is to allow an electric current to pass in one direction and to block the current in the opposite direction. The diode is a unidirectional electronic component. It must be used as shown in **Fig. 5.2** to work properly.

**NOTE:** The motor travel direction can be reversed by swapping the motor connections. An opportunity to confirm the correct motor polarity is provided during the limit setup procedure.

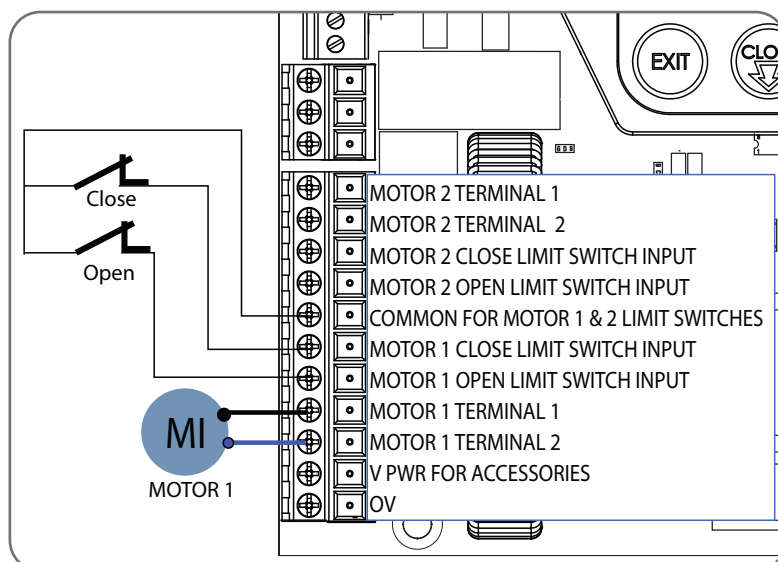

Fig 5.1

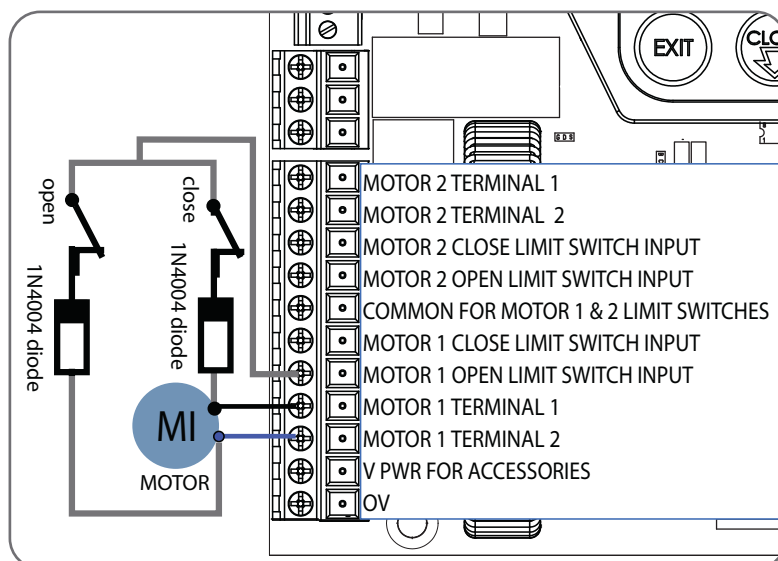

Fig 5.2

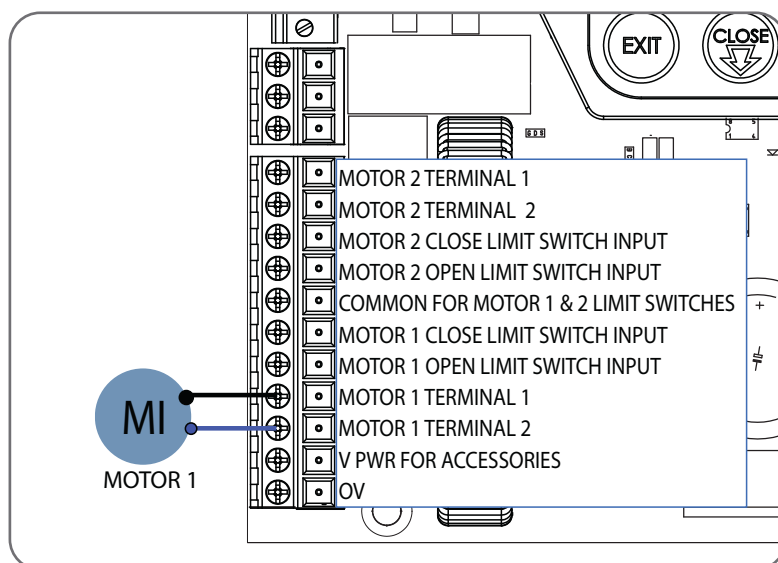

Fig 5.3



# 6. Wiring Diagrams - Dual Gates



**CAUTION:** Cables which have a green/yellow coloured insulation are for earthing purposes only. Never use these cables for any other purpose.

Fig 6.1

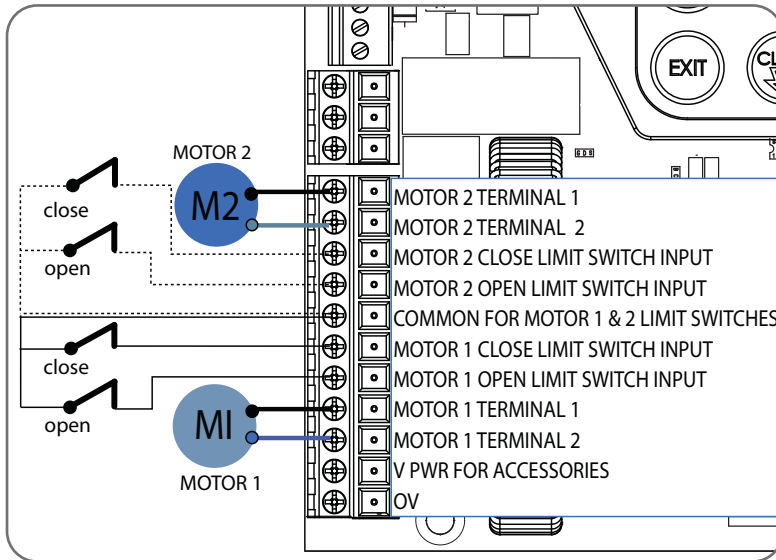

Fig 6.2

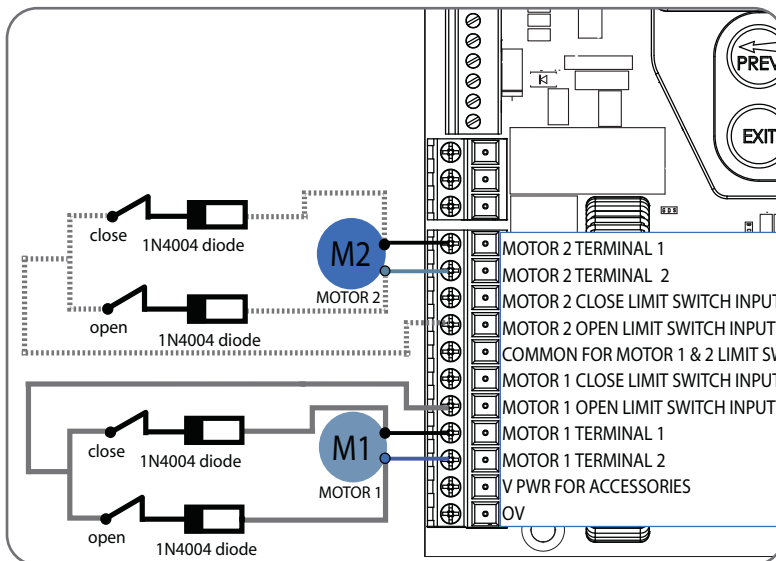
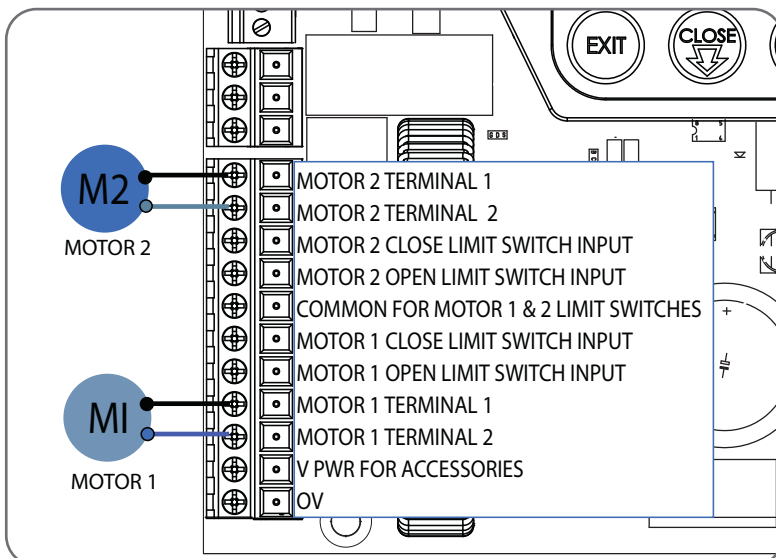

Fig 6.3



## 6.1 Wiring motors and limit switches

DCB-05V2 can be connected to the dual gate drive units in one of several ways.

Wiring	Figure #
5 Wire Dual Gate	6.1
3 Wire Dual Gate	6.2
2 Wire Dual Gate	6.3

The diagrams (Fig. 6.1 to Fig. 6.3) show the various wiring methods used for different drive unit types. Select the appropriate method for your drive unit.

**NOTE:** "non-motor current carrying limit-switch" type drive units can be connected using the standard 5 wire connections or a special 3 wire method that uses a single limit switch sense wire and four diodes.

## 6.2 Diodes 1N4004 or equivalent (not included)

The most common function of a diode is to allow an electric current to pass in one direction and to block the current in the opposite direction. The diode is a unidirectional electronic component. It must be used as shown in Fig. 5.2 to work properly.

**NOTE:** the drive unit connected to the MOTOR 1 terminals will open first and will be used for pedestrian access.

**NOTE:** The motor travel direction can be reversed by swapping the motor connections. An opportunity to confirm the correct motor polarity is provided during the limit setup procedure.



# 6. Wiring Diagrams - Dual NeoSlider Kit

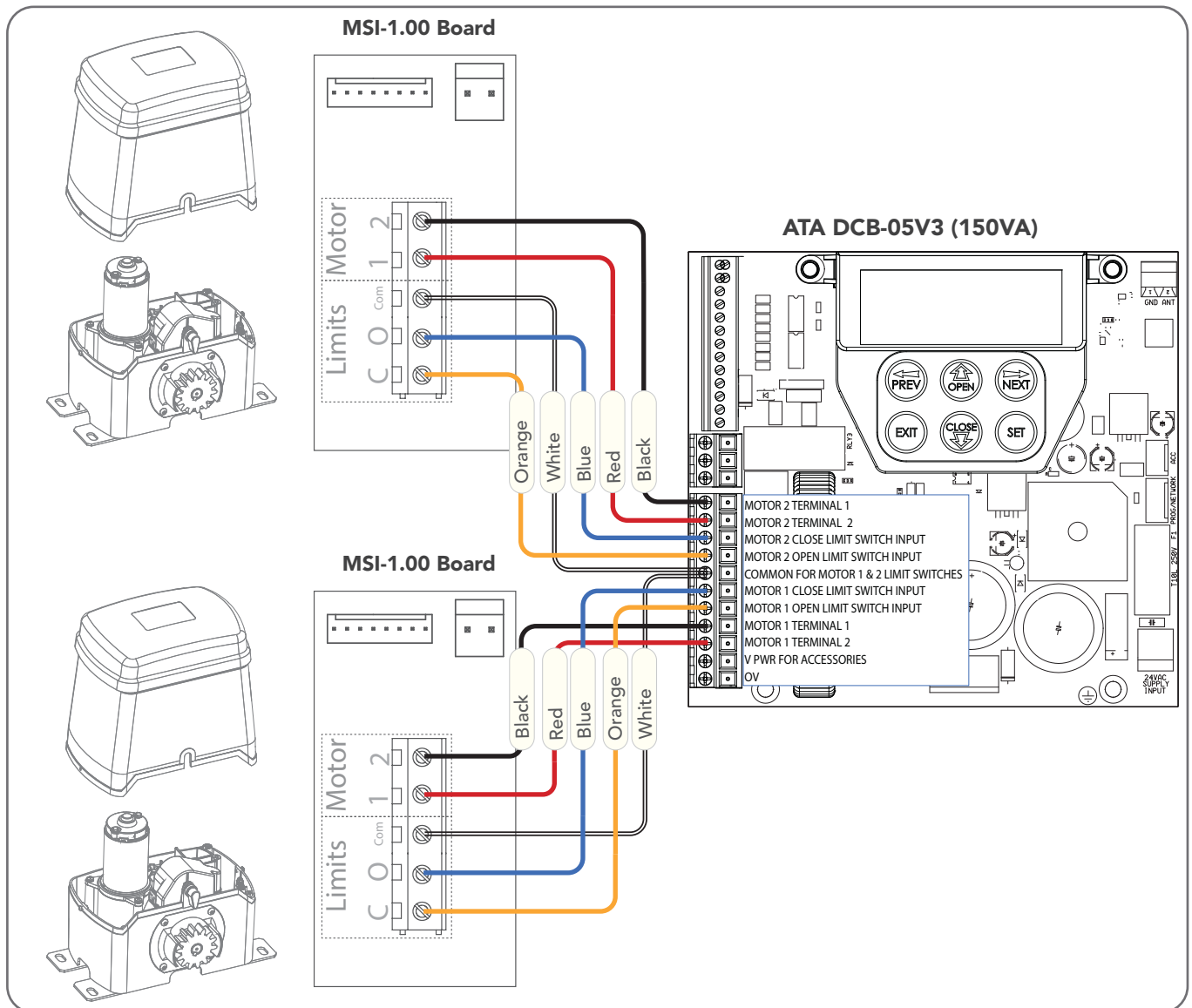

Fig 6.4

## 6.3 Dual NeoSlider Kit

This section illustrates how to wire two NeoSlider™ slave openers into a DCB-05V2. (Fig. 6.4)

### NOTE:

When setting limits, if both openers are travelling in different directions (i.e one is opening and the other is closing), then do the following:

- Switch over the motor wires (marked red and black in Fig 6.4) on the incorrectly behaving openers MSI board.
- Restart the limit set up process.



# 7. Programming the DCB-05V2

## 7.1 Common Programs

The two most common programs are;

Program	Menu's required	Function	Section
Automated Set Up	Menu 10.1	Setting the Limits	8.1
		Safety Obstruction Force	9.1 and 9.2
	Menu 1	Coding the Transmitter	10.1
Automated Set Up with Safety Beams	Menu 10.1	Setting the Limits	8.1
		Safety Obstruction Force	9.1 and 9.2
	Menu 1	Coding the Transmitter	10.1
	Menu 3	Auto Close Times	13.2, 13.3 and 13.4

Fig 7.1

**NOTE:** Fitting Safety Beams enables the Auto-Close feature to become active.

 **CAUTION:** Before plugging the gate control system in, check the power cord for damage and ensure it cannot become entangled in any moving parts

## 7.2 Powering up the DCB-05V2

- After checking the initial wiring, apply power to the DCB-05V2. The controller will go through a startup sequence displaying the STARTUP SCREEN which indicates the controller type and firmware version (**Fig. 7.2**). After a short delay the MAIN SCREEN will be displayed.
- If this is the first time the DCB-05V2 has been used, the MAIN SCREEN should indicate that the limits are not set (**Fig. 7.3**). If the display shows that some input is active then rectify the situation before proceeding. If a default setting is to be changed it should be done now before setting the travel limits.

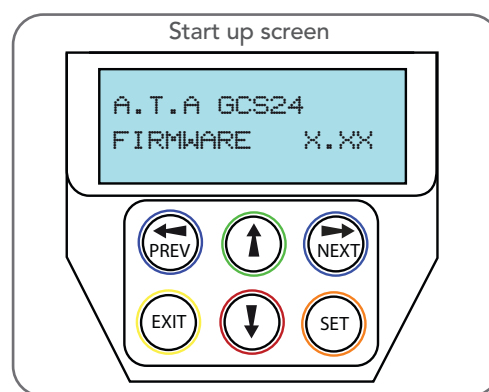

Fig 7.2

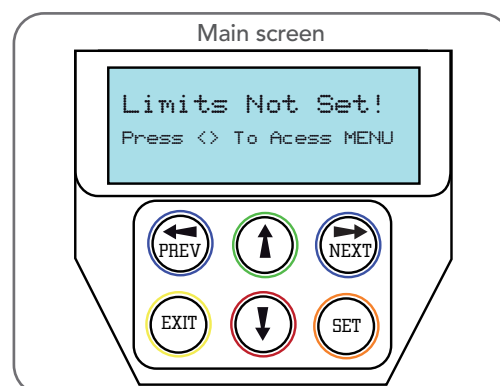

Fig 7.3

# 8. Setting Limits

DCB-05V2 can be used with drive units that use different methods to stop at the end of their travel.

The types supported are:

Wiring	Type
3 or 5 Wire setup	Limitswitch-Openandcloselimitswitchesindicate to DCB-05V2 when the travel limit is reached
2 Wire setup (See Appendix H & I for instructions)	AMP trip limits - Travel limits are detected by and an increase in motor current as mechanical stops are reached.
	Timing - The motor is driven for a preset time. When the travel limit is reached a clutch incorporated into the drive unit allows the motor to keep turning for the remaining preset running time.

## 8.1 Setting Travel Limits

Navigating To "Limit/AMP Travel Menu"

- Scroll to the right using next button to access MENU 10
- Press SET to display MENU 10.1.
- Press SET again to start the limit setting procedure (**Fig. 8.1**).
- DCB-05V2 will prompt you to confirm that the motor wiring is complete (**Fig. 8.2**) and that the gate(s) are at fully open position and engaged.
- Press SET to confirm.
- DCB-05V2 will now automatically detect the type of drive unit used by the number of wires used. If the correct number of wires is displayed then press SET to continue otherwise press EXIT and check the wiring.

**NOTE:** For 2 Wire Setup refer to Appendix H for "AMP Travel"

- DCB-05V2 will now automatically detect if one or two motor are connected. If the correct number is displayed then press SET to confirm. Otherwise press EXIT and check the wiring (**Fig. 8.3**).

## 8.2 Adjusting Close Limit(s)

- DCB-05V2 will prompt one at a time for the motor(s) to be driven to the desired close limit and for the limit switches to be adjusted so that the motor stops at the desired position.
- Drive the motor using the UP and DOWN arrows on the console keypad (**Fig. 8.4**).
- After making adjustments to the limit switch positions always re-approach the limit at full speed by driving the motor open a short distance and then driving it close again.
- When the close limit is adjusted to the desired position press SET to continue.

**NOTE:** If the motor drives in the wrong direction (UP closes gate / DOWN opens gate) the motor wires need to be swapped

## 8.3 Adjusting Open Limit(s)

- DCB-05 will now prompt for the motor(s) to be driven to the desired open limit and for the limit switches to be adjusted so that the motor stops at the desired position.
- Drive the motor using the UP and DOWN arrows on the console keypad.
- After making adjustments to the limit switch positions always re-approach the limit at full speed by driving the motor close a short distance and then driving it open again.
- When the open limit has been adjusted to the desired position, press SET.

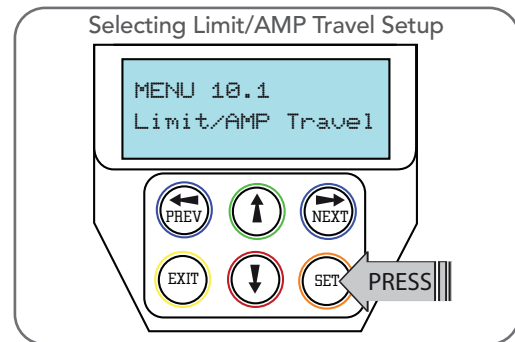

Fig 8.1

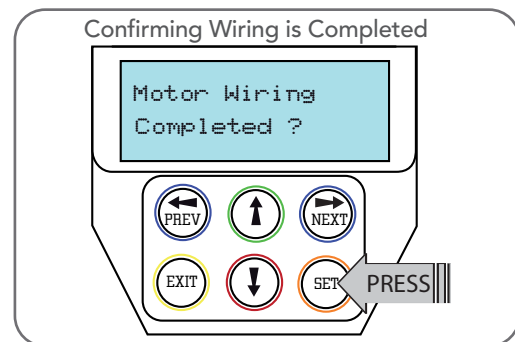

Fig 8.2

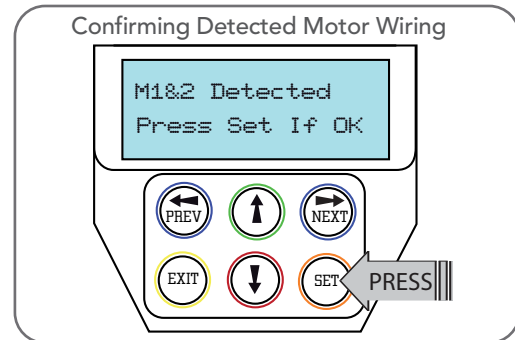

Fig 8.3

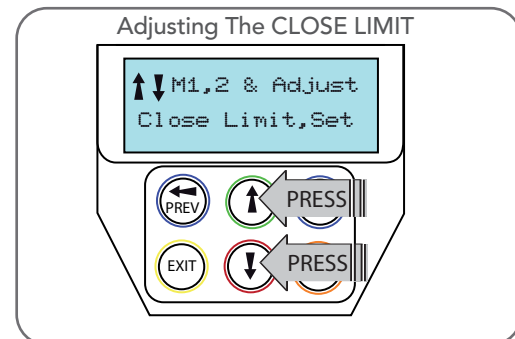

Fig 8.4

## 8.4 Automatic Profiling

After a brief pause DCB-05V2 will automatically close and open gate several times and learn the gate(s) load and travel characteristics.



**WARNING:** The gate(s) will automatically close and open. Ensure that no persons or objects are in the gates path.

When the setup is complete the MAIN SCREEN will be displayed with the gate shown to be OPEN. The Gate can now be used.

# 8. Setting Limits: Via Transmitter

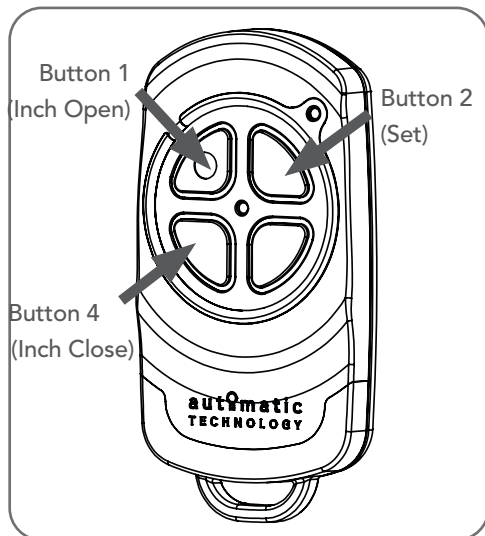

Fig 8.5

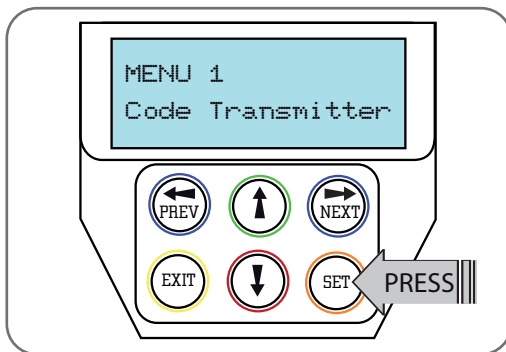

Fig 8.6

**IMPORTANT NOTE:** Only TrioCode™ 128 Technology Transmitters are compatible with this product.

The DCB-05V2 has the alternate ability to set travel limits using a transmitter, allowing free movement around the gate to better assess the desired limit positions. In order to use a transmitter, it must first have at least one of its buttons coded to the gate controller. The function assigned to the transmitter's buttons is of no concern here as the buttons are temporarily assigned to OPEN, CLOSE and SET (Fig. 8.5).

## 8.5 Code A Transmitter For Limit Setting

Navigating to "code transmitter" menu

- Press NEXT to navigate to Menu 1.
- Press SET to enter the code set procedure (Fig. 8.6).

Storing Transmitter Code

- Controller will prompt to press one of the transmitter's Button.
- Press the transmitter button you wish to use to operate the gate opener (e.g. button 1).
- Press the same transmitter button again as prompted by display.
- Press the SET button to store the transmitter.

Navigating To "Set Gate Travel Menu"

- Press PREV to navigate to Menu 10.
- Press SET to display MENU 10.1.
- Press SET two times to enter the limit setting procedure. Follow LCD prompts.

## 8.6 Setting Limits Via Transmitter

- Press and hold Button 4 on the transmitter to close the gate
  - If the gate is closed too far, press Button 1 to "inch" the gate towards open.
  - When happy with the close limit position, press Button 2 to store this in the memory.
- Press Button 1 to open the gate.
  - If the gate is opened too far, press Button 4 to "inch" the gate towards close



**WARNING:** The gate will automatically close and open once next step is performed. Ensure that no persons or objects are in the gates path.

- When happy with the open limit position, press Button 2 on the transmitter to store into memory.
- The gate will now automatically close and open to calculate the safety obstruction settings.

# 9. Safety Obstruction Force Test

**WARNING!** Take care when testing or adjusting the Safety Obstruction Force. Excessive force may cause **SERIOUS PERSONAL INJURY** and/or **PROPERTY DAMAGE**.

## 9.1 Testing Close Cycle (Single Swing Gates)

- Press the OPEN button to open the gate.
- Place a piece of timber approximately 40mm high on the ground directly next to the closing pylon / fence (**Fig. 9.1**).
- Press the CLOSE button to close the gate. The leaf of the gate should strike the object and start to re-open.

## 9.2 Testing Open Cycle (Single Swing Gates)

- Press the CLOSE button to close the gate.
- Press the OPEN button to open the gate. When the gate reaches the half open point, grab the side rail of the gate firmly and the gate should stop.
- If the gate does not reverse readily when closing, or stop when opening, the force may be excessive and need adjusting.

**WARNING!** If the gate fails these tests, put the opener into manual mode, only operate the gate by hand and call for service.

### Safety Obstruction Force

The Safety Obstruction Force is calculated automatically during setup. Adjusting this is normally only necessitated by environmental conditions such as windy or dusty areas, and areas with extreme temperature changes.

## 9.3 Force Pressure For Close Cycle.

### Navigating To "Current Trips"

- Press NEXT or PREV to navigate to Menu 2 Current Trips.
- Press SET (**Fig. 9.2**)
- MENU 2.1: CLOSE Margin is displayed (**Fig. 9.3**).
- Press UP arrow to increase or DOWN arrow to decrease the value.
- Press SET to save the new value.

**NOTE:** For dual gates repeat the same process for Motor 2  
f. Test the force again as per "Safety Obstruction Force Test" in Section 9.1.

## 9.4 Force Pressure For Open Cycle.

### Navigating To "Current Trips"

- Press NEXT to navigate to the Menu 2 Current Trips.
- Press SET (**Fig. 9.2**)
- Press NEXT.
- MENU 2.2: OPEN Margin is displayed.
- Press UP arrow to increase or DOWN arrow to decrease the value.
- Press SET to save the new value.

**NOTE:** For dual gates repeat the same process for Motor 2  
g. Test the force again as per "Safety Obstruction Force Test" in Section 9.2

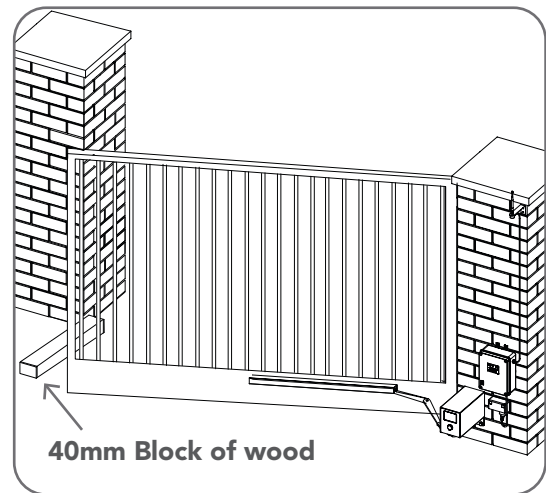

Fig 9.1

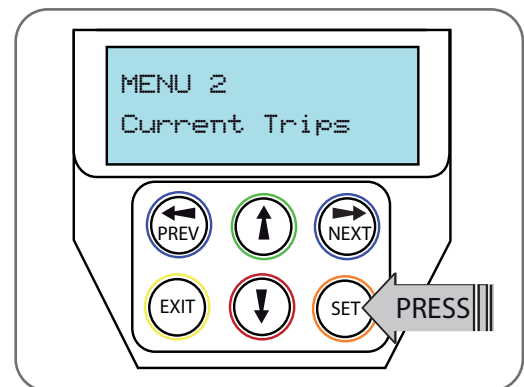

Fig 9.2

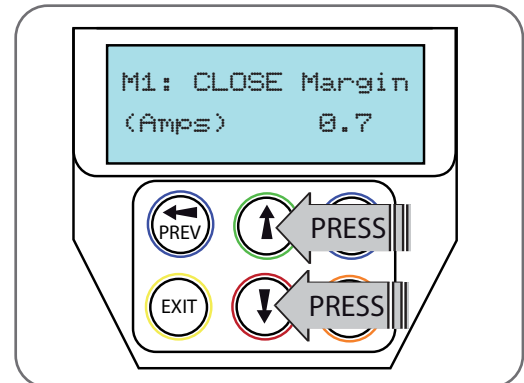

Fig 9.3

## 9.5 Reprofile Travel

- Reprofiling is a simplified way of re-learning the travel characteristic of a previously setup Limit Switch travel installation. Re-profiling can be used when the travel characteristics of the gate(s) change due to mechanical adjustments etc. To initiate a re-profile, simply locate "MENU 10.3 Repofile Travel", press SET and follow the prompts. The gate(s) will start to move and re-calculate force margins. The gate(s) can move between the open and close limit positions up to two (2) times (depending on the position of the gate(s) and the power up condition).
- A single beep will be heard once the process is complete.
- Test the force again as per "Safety Obstruction Force Test" (Section 9.1 and 9.2).

# 10. Coding Transmitter

DCB-05V2 can store up to thirty (30) transmitters in its memory. Each transmitter can be allocated an alpha-numeric ID label up to eleven (11) characters in length and each button can be assigned to one of several control functions. The settings for a transmitter are represented in (Fig. 10.1). It shows the transmitter's store number, ID label or serial number and the functions assigned to each of its four buttons. To toggle between ID/SN display, press UP/DOWN with the cursor on the ID/SN indicator. The procedures below code, delete, replace, edit and copy transmitter records.

**IMPORTANT NOTE:** Only TrioCode™128 Technology Transmitters are compatible with this product.

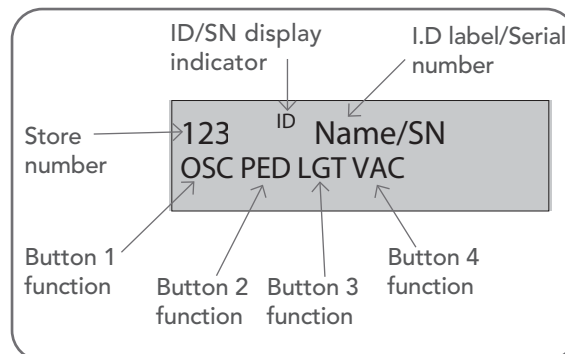

Fig 10.1

## 10.1 Coding Transmitter Button

Navigating To Menu 1 "Code Transmitter"

- Press NEXT to navigate to Menu 1.
- Press SET to enter the code set procedure.

### Storing Transmitter Code

- The controller will prompt to press one of the transmitter's buttons.
- Press the transmitter button you wish to use to operate the Gate Opener (e.g. button 1) (Fig. 10.2).
- Press the same transmitter button again as prompted by the display.

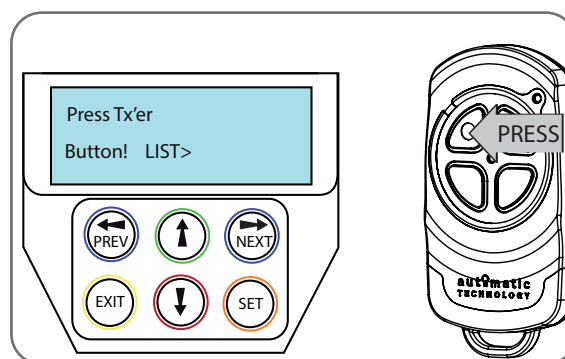

Fig 10.2

## 10.2 Selecting Function Of The Button

The controller will now show the transmitter's record, with a cursor on the field for the button being coded (Fig. 10.3). Use UP/DOWN arrows to select the function for the button.

Available functions:

- |                         |                       |
|-------------------------|-----------------------|
| VAC (Vacation Mode)     | LGT (Courtesy Light)  |
| STP (Stop)              | OPN (Open)            |
| CLS (Close)             | SWP (Swipe)           |
| PED (Pedestrian access) | OSC (Open/Stop/Close) |
| OFF (No action)         |                       |

Press SET to save the settings or EXIT to abort without saving.

## 10.3 Returning To Main Screen

The "Code Transmitter" menu will now be shown. Press EXIT to return to the MAIN SCREEN and test the transmitter.

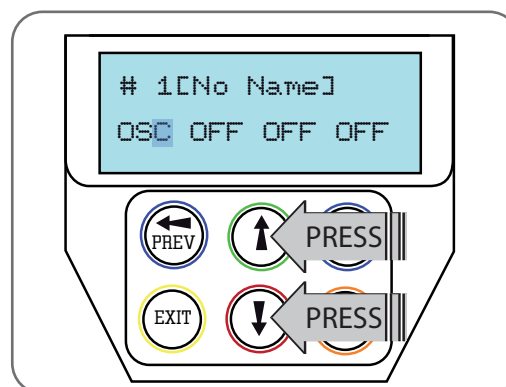

Fig 10.3

# 11. Remotely Coding Transmitters

If a transmitter is already coded into the opener, additional transmitters can be coded without being in direct contact with the DCB-05V2.

**NOTE:** Only the function of the existing transmitter button can be assigned to new transmitter. Please read instructions prior to proceeding - there is a time-out facility for security reasons.

## 11.1 Selecting The Function To Be Coded

- Using the existing transmitter, operate the gate with the transmitter button which has the function to be coded (e.g. Button 1 has been coded with the OSC function assigned).
- If the button's function activates the gate (PED, SWP, OSC, CLS, STP or OPN) wait for the gate to complete its cycle.



Fig 11.3

# 11. Remotely Coding Transmitters

Fig 11.2

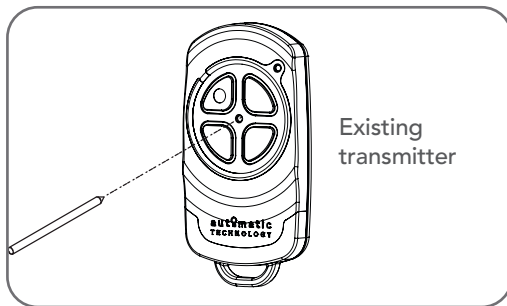

## 11.2 Activate Remote Code Set Mode

- Use a small pin to press and hold through the Coding Hole of the existing transmitter for 2 seconds (**Fig. 11.2**).
- Within 10 seconds, press the button on the new transmitter you wish to code for 2 seconds (**Fig. 11.3**).
- Press the same button again (within 10 seconds) for confirmation.
- Test Operation. The new transmitter button should now function as the existing transmitter.

**NOTE:** When a transmitter is remotely coded, its ID label is set to that of the existing transmitter. If the existing transmitter does not have an ID label assigned, then the ID label of the new transmitter is set to: R/C Tx ###, where ### is the existing transmitters store number. This ensures that the originator of any remotely coded transmitter can be identified.

Fig 11.3

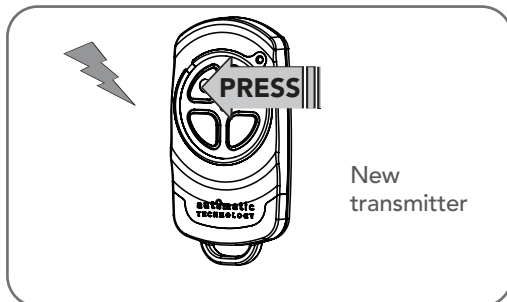

# 12. Setting Pedestrian Position

DCB-05V2 can be instructed, via its pedestrian control feature, to partly open and provide pedestrian access but prevent vehicle access. This is achieved by partly opening the motor 1's gate leaf. If dual motors are used, motor 2's gate leaf is held closed. The partly open position of motor 1's gate leaf is initially set to a position halfway between open and closed. This initial position can be adjusted by the installer to any position within the gates travel range by selecting a pedestrian access travel time (from closed). The setting is accessed from "MENU 10.4 Set Pedestrian". The time is adjustable in 1 second steps.

Fig 12.1

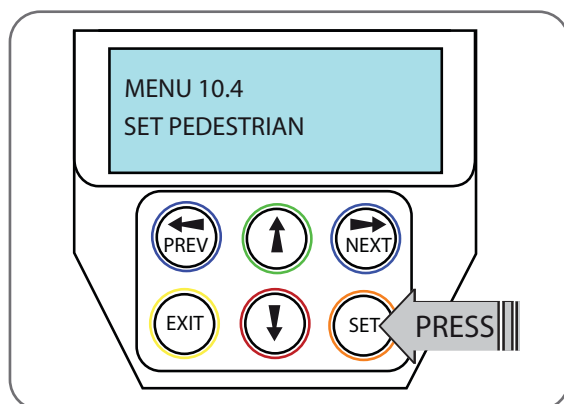

**NOTE:** Before setting the pedestrian access position the gate must be in the fully closed position. As with the Setting Travel Limit procedure, a transmitter can be used to complete the pedestrian position setting procedure.

## 12.1 Setting the Pedestrian Position

Navigating to "Menu 10.4 Set Pedestrian"

- Press PREV to navigate to Menu 10.
- Press SET - MENU 10.1 is displayed.
- Press NEXT to go to MENU 10.4.
- Press SET to enter Set Pedestrian procedure (**Fig. 12.1**).

Setting pedestrian position

- Press UP or DOWN arrows to adjust pedestrian drive time.
- Press SET to record position
- Press transmitter coded for pedestrian function or push button wired into pedestrian input to test.

Fig 12.2

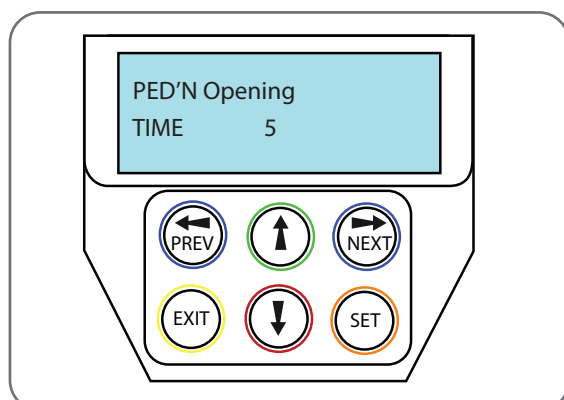

## 12.2 Checking Pedestrian Position

When activated by a transmitter button which is coded as Ped mode, the opener drives the gate to the preset position. Ped Mode's active status is indicated on the display (**Fig. 12.2**). If a Ped Mode button is pressed while the gate is moving, the gate will stop. If a Ped Mode button is pressed when the gate is in the Ped position, then the gate will close.

## 12.3 Error Displays

During the above procedure many error checks are performed. If an error is detected, a message will be displayed indicating the error.

# 13. Auto-Close Mode



**WARNING! The Auto-Close function is not available unless Safety Beams are installed.**

## 13.1 Setting Up Standard Auto-Close

### Menu 3. Auto-Close Times

Auto-Close mode is a function that automatically closes the gate a preset time after the Safety Beam recognise that a vehicle has left the gateway. The Auto-Close timer only starts after the Safety Beam path is broken and the Auto-Close timer has been set. If the Safety Beam path is not broken, the gate will remain open until the path is broken. If the opener incurs a physical obstruction (i.e. not from the Safety Beam) while closing, the gate will re-open and not Auto-Close until the Safety Beam path is broken again.

### Menu 3.1 Auto-Close

This mode is selected by entering a non-zero time for the STD Auto-Close parameter. When selected, the gate will Auto-Close after being fully opened (except when the gate has reversed to the open position after a motor obstruction or overload unless A/C after open and/or close Obstruction are selected). Countdown is suspended by: S.B., OPN or SWP input being active. The countdown is aborted if the STP input is activated. If the gate is already open and the OPN or the SWP input is activated, then the countdown will start.

## 13.2 Safety Beam Triggered Auto Close

### Menu 3.2 (SB AC Trig)

This mode is selected by entering a non-zero time for the "Safety Beam Auto-Close" parameter. This mode is used to Auto-Close the gate but only after an object has passed through the gateway and has triggered the Safety Beam input. Any Safety Beam or combination of Safety Beams can be configured to activate Safety Beam Auto-Close mode and combinations are:

#### One Beam only

- i. Safety Beam 1
- ii. Safety Beam 2

#### Either Beam

- i. Safety Beam 1 or Safety Beam 2

#### Combination

- ii. Safety Beam 1 and Safety Beam 2
- iii. Safety Beam 2 then Safety Beam 1

**NOTE:** The swipe input can be used to clear the Safety Beam triggered status so that the Safety Beam input must be activated again before the countdown will start. As with the other Safety Beam modes, the STP input will abort countdown and the OPN and SWP inputs will restart the countdown if the gate is OPEN.

## 13.3 Pedestrian Auto-Close

### Menu 3.3 Pedestrian Auto-Close

This mode is selected by entering a non-zero time for the "Ped'n A/C" parameter. When selected, the gate will Auto-Close after being opened for pedestrian access unless it was following a reverse from an obstruction.

### Menu 3.4 (Safety Beam) Pedestrian Triggered Auto-Close

This mode is selected by entering a non-zero time for the "Safety Beam Pedestrian Auto-Close" parameter. Any Safety Beam or combination of Safety Beams can be configured to activate Safety Beam Auto-Close mode and combinations are:

#### One Beam only

- iv. Safety Beam 1
- v. Safety Beam 2

#### Either Beam

- i. Safety Beam 1 or Safety Beam 2

#### Combination

- ii. Safety Beam 1 and Safety Beam 2
- iii. Safety Beam 2 then Safety Beam 1

## 13.4 Auto-Close After Obstruction:

Two parameters are provided to enable the Auto-Close feature to be activated after obstructions and power up. Normally the Auto-Close feature is not enabled after obstructions for safety reasons. Safety Beams must be used for these features to be activated.

### Menu 3.5

This mode enables the Auto-Close feature to be activated when a close obstruction occurs (requires Safety Beams).

### Menu 3.6

This mode enables the Auto-Close feature to be activated when an open obstruction occurs.

### Menu 3.7

This mode enables Auto-Close feature after power up.



# 14. Accessories Installation

## Wiring Output1 And Output2

Outputs 1 and 2 are used to control a lock and a light. Which output is to control which function and the way it is controlled is programmable. If using these outputs make sure that the functions are configured for correct operation prior to setting the travel limits. OUTPUT1 is a relay output with high current capability. OUTPUT2 is used to activate an optional external relay module (RO-1) which in turn is used to switch the load.

### 14.1 Fitting Solenoid Or Magnetic Locks

Install the lock mechanism on the gate as per the manufacturers instructions. See **Fig. 14.1** for the wiring diagram.

#### Menu 4. Lock Times

Lock output can be programmed for both hold and pulse mode. The operation of the lock can be programmed to activate prior to the gate and behave differently on open cycles to that on close cycles.

- Press NEXT or PREV on the wall control unit to navigate to Menu 4 Lock Times.
- Press SET to select the sub menu.
- Press NEXT or PREV to navigate through the sub menu.
- Press OPEN to increase or CLOSE to decrease the time.
- Press SET to save the new time.
- Press the EXIT button two times to exit and test the locks operation.

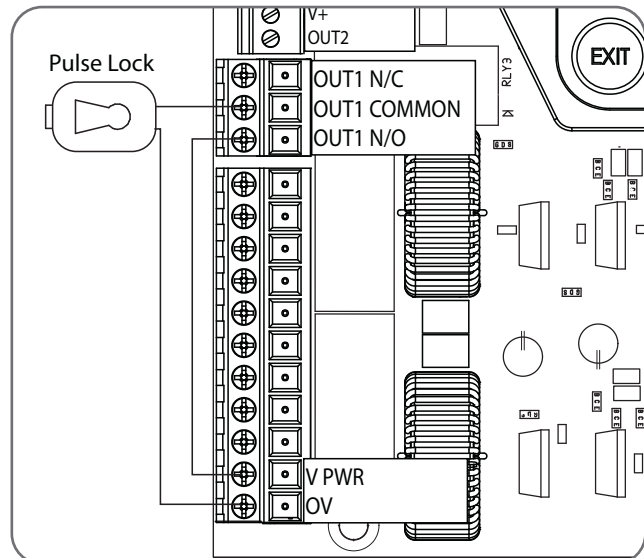

Fig 14.1

### 14.2 Fitting Courtesy Lights

An AC or DC courtesy light can be activated via an output on the gate opener control board. Connect the light as per the diagram. (**Fig. 14.2**)

**WARNING: A qualified electrician must perform the installation where 240V AC power is used.**

#### Menu 5. Light Times

- Press NEXT or PREV on the wall control unit to navigate to Menu 5 Light/Lock Times.
- Press SET to select the sub menu.
- Press NEXT or PREV to navigate through the sub menu.
- Press OPEN to increase or CLOSE to decrease the time.
- Press SET to save the new time.
- Press the EXIT button two times to exit.
- Test the light operation.

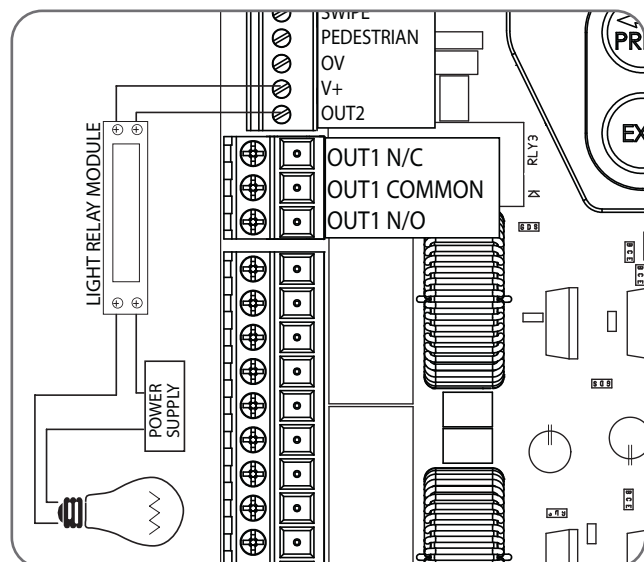

Fig 14.2

# 15. Battery Replacement

Battery Type:

3V Lithium Battery CR2032.

- To test the battery is working, press and hold a transmitter button. Check Light Status table to determine if battery needs replacing

Light Status	Battery Status
Solid	OK
Flashing	Requires replacement
No light	Requires replacement

- Use a screwdriver to remove the screw on the back of the transmitter casing.
- Use the screwdriver to pry open the plastic to expose circuit board.
- With a non-metallic object (e.g. pen) remove the battery.

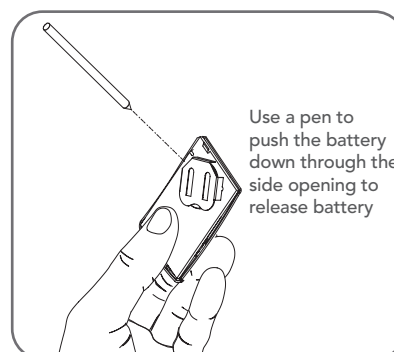

Use a pen to push the battery down through the side opening to release battery



**WARNING! Chemical Burn Hazard. Keep batteries away from children**



# 16. Battery Disposal

When batteries reach the end of their usual life in accordance with Australian Battery Recycling Initiative please follow the next simple steps for protecting the environment. Refer to the Automatic Technology website for information on where to recycle batteries in Australia.



**WARNING! The Battery shall be disposed of properly, including keeping them away from children. Even used batteries may cause injury.**



**DO NOT throw the batteries in municipal waste. This symbol of the crossed out wheeled bin indicates that the battery should not be placed in the municipal waste. Check your local regulations for appropriate disposal of the batteries.**

Recycling all batteries will have other environmental and social benefits:

- Some batteries are less toxic but hazardous for other reasons. Lithium batteries can explode or catch fire in landfill, while button cells are dangerous if swallowed by children. Recycling offers a safe and environmentally responsible solution for end of life batteries.
- Battery recycling recovers non-renewable materials such as lead, cadmium, stella, zinc, manganese, cobalt, silver, plastics and rare earth elements.
- Removal of batteries and other hazardous household products from household waste facilitates the recovery of organic materials through alternative waste technologies such as composting. Batteries and heavy metals are known contaminants in compost.
- The community supports recycling because it reduces waste to landfill and achieves environmental benefits.



**WARNING! Prior to disposal, recycling, or collection, all battery terminals must be securely insulated with a non conductive material to prevent any two batteries from short circuiting and generating heat during storage or transport. Battery terminals may be insulated with electrical tape; or batteries may be individually packaged in a non conductive material (e.g., plastic bag or original packaging).**

# 17. Specifications

Technical Specifications	
Protection rating:	IP56 (only when unit is sealed with correct cable glands)
24VDC accessory output	24VDC (unfiltered) 3Amp maximum
Secondary voltage:	24V AC
Motor voltage:	12 to 24V DC @ 10AMPS max combined
Receiver type:	TrioCode™128 Technology
Receiver code storage capacity:	30 x 4 Button Transmitter Codes
Transmitter frequency:	433.92 MHz
Coding type:	Hopping Code
No. of code combinations:	Over 100 billion random codes
Code generation:	Non-linear encryption algorithm
Transmitter battery:	CR2032

**NOTE:** Specifications are subject to change without notice.



# 18. Troubleshooting

Symptom	Possible cause	Remedy
Gate will not operate	Mains power not switched on.	Switch on mains power.
	Control Box not wired correctly	Check all wiring from motor and microswitches to the control board are sound (Section 5)
	Opener motor is disengaged	Check that the motor is engaged for automatic operation
	Gate is obstructed.	Remove obstruction.
	The opener is in "Vacation Mode"	Turn off "Vacation Mode"(Appendix C Menu 7.4).
Gate starts to close but automatically reverses to open position	Adverse weather conditions (wind or cold) causing gate to stiffen and become tight in the tracks.	Increase force margin setting (Section 9.4)
	Possible obstruction in the doorway.	Remove obstruction
Gate operates from control box but not from transmitter	Transmitter code not stored in memory.	Code transmitter in to openers memory. (Section 10.1)
	Transmitter does not contain TrioCode™128 Technology	Check the transmitter. It should have grey buttons and the model number should display V2. Contact dealer for support if otherwise.
	Flat battery in transmitter	Replace battery (Section 15)
	Antenna behind structure (gate or fence) or not in line of sight	Ensure Antenna is in line of sight (Section 4.2)
Gate does not close with transmitter	Safety Beam not working properly.	Make sure Safety Beams are operational. and no dirt is on the lens.
Gate will not close fully.	Gate limit positions need to be reset.	Reset limits positions.
	Gate obstructed and reverses	Clear obstruction or adjust force margin (Section 9.3)
Door will not open fully.	Gate limit positions need to be reset.	Reset limits positions. (Section 8)
	Gate obstructed.	Clear obstruction or adjust force margin (Section 9.3)
Auto-Close not working	Safety Beam not installed.	Install Safety Beam. (Refer to Safety Beam Manual)
	Safety Beam or wiring faulty.	Repair Safety Beam or replace wiring.
	Safety Beam not aligned correctly.	Re-align optics.
	Safety Beam is obstructed.	Remove obstruction from path of Safety Beams.
	Gate obstructed when closing.	Remove obstruction.
	Auto-Close time not set.	Set Auto-Close times (Section 13.3).
	Auto-Close mode not set	Set Auto-Close mode. (Section 13.2)



# 19. Appendix

## A - Console Menu Structure

### OPERATIONAL BUTTONS:

1. Press PREV/NEXT buttons move to Left/Right.
2. Press OPEN/CLOSE buttons to change setting.
3. Press SET button to save changes.
4. Press EXIT to return to MENU without saving changes.

Parameter	Min	Max	Default	Step	Unit	Menu	Section
Menu 1 - Code Transmitter							
STORING TRANSMITTERS	0.0	511				1	10.1
Menu 2 - Current Trips							
Parameter (Limit Switch)							
M1 MARGIN Sets obstruction detection margin for M1	0.0	5.0	0.7	0.1	AMPS	2.1	9.3
M2 MARGIN Sets obstruction detection margin for M2	0.0	5.0	0.7	0.1	AMPS	2.2	9.3
SETTLE TIME disable the obstruction detection in the start of the cycle	0.1	2.0	1.0	0.1	SEC	2.3	
Parameter (AMP Limits)							
STOP DETECT MARGIN AMPS	0.0	5.0	1.5	0.1	AMPS	2.4	Appendix H
Motor 1 Open Limit AMPS Sets Motor 1 open limit detection current	0.0	8.0	AUTO	0.1	AMPS	2.5	Appendix H
Motor 1 Close Limit AMPS Sets Motor 1 close limit detection current	0.0	8.0	AUTO	0.1	AMPS	2.6	Appendix H
Motor 2 Open Limit AMPS Sets Motor 2 open limit detection current	0.0	8.0	AUTO	0.1	AMPS	2.7	Appendix H
Motor 2 Close Limit AMPS Sets Motor 2 close limit detection current	0.0	8.0	AUTO	0.1	AMPS	2.8	Appendix H
Maximum startup amps sets maximum permitted starting current of motors	0.0	6.0	5.0	0.1	AMPS	2.9	Appendix H
Parameter (timed travel)							
Cutout AMPS maximum motor current permitted after startup	0.0	10.0	10.0	0.1	AMPS	2.10	Appendix H
Menu 3 - Auto Close							
STD AUTO-CLOSE TIME Sets and enables the standard Auto-Close time	0.0	300.0	0.0	1.0	Sec	3.1	13.1
SAFETY BEAM AUTO-CLOSE TIME Sets and enables the SB triggered Auto-Close time	0.0	60.0	0.0	1.0	Sec	3.2	13.2
PEDESTRIAN AUTO-CLOSE TIME Sets and enables the Pedestrian Auto-Close time	0.0	60.0	0.0	1.0	Sec	3.3	13.3
SAFETY BEAM PEDESTRIAN AUTO-CLOSE TIME Sets and enables the SB Pedestrian Auto-Close time	0.0	60.0	0.0	1.0	Sec	3.4	13.3
AUTO-CLOSE AFTER CLOSE OBSTRUCTION Enables Auto-Close feature after close obstructions	Off	On	Off			3.5	13.4
AUTO-CLOSE AFTER OPEN OBSTRUCTION Enables Auto-Close feature after open obstructions	Off	On	Off			3.6	13.4
AUTOCLOSE AFTER POWERUP Enables autoclose feature after powerup	Off	On	Off			3.7	13.4
Menu 4 - Lock Times							
OPEN LOCK TIME Set the time the lock is activated for on open cycles	0.0	Hold	0.5	0.1	Sec	4.1	14.1
CLOSE LOCK TIME Set the time the lock is activated for on close cycles	0.0	Hold	0.5	0.1	Sec	4.2	14.1
PRE-OPEN LOCK TIME Time the lock is activated for prior to opening	0.0	25.5	0.0	0.1	Sec	4.3	14.1
PRE-CLOSE LOCK TIME Time the lock is activated for prior to closing	0.0	25.5	0.0	0.1	Sec	4.4	14.1

# Appendix

## A - Console Menu Structure

Parameter	Min	Max	Default	Step	Unit	Menu	Section
Menu 5 - Light Times							
ON AFTER CYCLE LIGHT TIME - Time light remains on for after a cycle	0	255	60	1	Sec	5.1	14.2
ON BEFORE OPEN CYCLE LIGHT TIME Minimum time light is activated for prior to opening	0	255	0	1	Sec	5.2	14.2
ON BEFORE CLOSE CYCLE LIGHT TIME Minimum time light is activated for prior to closing	0	255	0	1	Sec	5.3	14.2
Menu 6 - Motor Settings							
CLOSE SYNC DELAY TIME Time delay between M2 and M1 closing	0.0	25.5	2.0	0.1	SEC	6.1	Appendix C
OPEN SYNC DELAY TIME Time delay between M1 and M2 opening	0.0	25.5	2.0	0.1	SEC	6.2	
OPEN SPEED VOLTS Voltage applied to motors when opening	12	24	22	1	VOLTS	6.3	
CLOSE SPEED VOLTS Voltage applied to motors when closing	12	24	20	1	VOLTS	6.4	
SLOW SPEED VOLTS Voltage applied to motors when slowing down	6	24	8	1	VOLTS	6.5	
SLOW TIME The time between slow down and end of cycle	0.1	10.0	3.0	0.1	SEC	6.6	
HOMING / SETUP SPEED VOLTS Voltage applied to motors when setting up the travel limits	12	24	Norm	1	Volts	6.7	
STOP PAUSE TIME Pause time used between motor direction changes	0.0	2.0	0.3	0.1	SEC	6.8	
M1 NORMAL OPEN TIME Normal open time for motor 1	0.0	60.0	0.0	0.1	SEC	6.9	
M1 NORMAL CLOSE TIME Normal close time for motor 1	0.0	60.0	0.0	0.1	SEC	6.10	
M2 NORMAL OPEN TIME Normal open time for motor 2	0.0	60.0	0.0	0.1	SEC	6.11	
M2 NORMAL CLOSE TIME Normal close time for motor 2	0.0	60.0	0.0	0.1	SEC	6.12	
M1 CLOSE DELAY Close Delay for Motor 1	0.0	25.5	0.0	0.1	SEC	6.13	
MAX OVERRUN TIME Extra time allowed for cycle to complete (beyond normal cycle time)	0	60	5	1		6.14	

# Appendix

## A - Console Menu Structure

Parameter	Min	Max	Default	Menu	Section
Menu 7 - Operating Modes					
SB1 TYPE	2 WIRE 3 WIRE	2 WIRE 3 WIRE		7.1	Appendix C
SB2 TYPE	2 WIRE 3 WIRE	2 WIRE 3 WIRE		7.2	Appendix C
SB1 INPUT MODE Sets the Input mode for Safety Beam 1. Only one option can be selected.	NOT USED, CLS TO REV CLS TO STOP OPN/CLS TO STOP OPEN INPUT SWIPE INPUT CLOSE INPUT PED INPUT DISABLED	NOT USED, CLS TO REV CLS TO STOP OPN/CLS TO STOP OPEN INPUT SWIPE INPUT CLOSE INPUT PED INPUT DISABLED On	NOT USED	7.3	Appendix C
SB2 INPUT MODE Sets the Input mode for Safety Beam 2. Only one option can be selected.	NOT USED, CLS TO REV CLS TO STOP OPN/CLS TO STOP OPEN INPUT SWIPE INPUT CLOSE INPUT PED INPUT DISABLED	NOT USED, CLS TO REV CLS TO STOP OPN/CLS TO STOP OPEN INPUT SWIPE INPUT CLOSE INPUT PED INPUT DISABLED On	NOT USED	7.4	Appendix C
PED INPUT = SWIPE MODE Selects PED input functions as pedestrian access swipe input	Off	On	Off	7.5	Appendix C
OPN INPUT N/C OPERATION Selects operating polarity of OPN input	Off	On	Off	7.6	Appendix C
STP INPUT N/C OPERATION Selects operating polarity of STP input	Off	On	Off	7.7	Appendix C
AUX INPUT OPERATION	LIGHT MOTOR ENGAGED	LIGHT MOTOR ENGAGED	LIGHT	7.8	Appendix C
VACATION MODE Selects vacation mode - disables remote control	Off	On	Off	7.9	Appendix C
REMOTE CODE ENABLED Selects remote transmitter coding function	On	Off	On	7.10	Appendix C
BATTERY/SOLAR MODE Selects Battery Backup/Solar operation	BATTERY ENABLED SOLAR ENABLED	BATTERY ENABLED SOLAR ENABLED	BATTERY ENABLED	7.11	Appendix C
PASSWORD Selects password protection for all changes	Off	On	Off	7.12	Appendix C
TX # GROUPING Selects transmitter number group display format.	Off	On	Off	7.13	Appendix C
OUTPUTS 1 MODE Selects function of OUTPUT1	LOCK DRIVE LIGHT DRIVE 3 WIRE SB 0V NOT USED	LOCK DRIVE LIGHT DRIVE 3 WIRE SB 0V NOT USED		7.14	Appendix C
OUTPUTS 2 MODE Selects function of OUTPUT2	LOCK DRIVE LIGHT DRIVE 3 WIRE SB 0V NOT USED	LOCK DRIVE LIGHT DRIVE 3 WIRE SB 0V NOT USED		7.15	Appendix C
FAULT AUTO RESET	Off	On	Off	7.16	Appendix C
SBFEC MODE	AVAILABLE DISABLED	AVAILABLE DISABLED	AVAILABLE	7.17	Appendix C

Parameter	Min	Max	Default	Menu	Section
Menu 8 - Diagnostics					
TEST INPUTS - Controls input display status			Inactive	8.1	Appendix D
TEST TRANSMITTERS (TX'ERS)				8.2	Appendix D
DISPLAY HISTORY				8.3	Appendix D
MEMORY USAGE				8.4	Appendix D
SERVICE COUNTER			60,000	8.5	Appendix D
EVENT COUNTER				8.6	Appendix D
Menu 9 - Memory Tools					
CLR CONTROL				9.1	Appendix E
CLR TRANSMITTERS (TX'ERS)				9.2	Appendix E
Menu 10 - Setup Travel					
SETUP LIMITS				10.1	8.1
TIME TRAVELED				10.2	Appendix H
REPROFILE TRAVEL				10.3	9.5
SET PEDESTRIAN				10.4	12.1

# Appendix

## B - Viewing and Editing Parameters

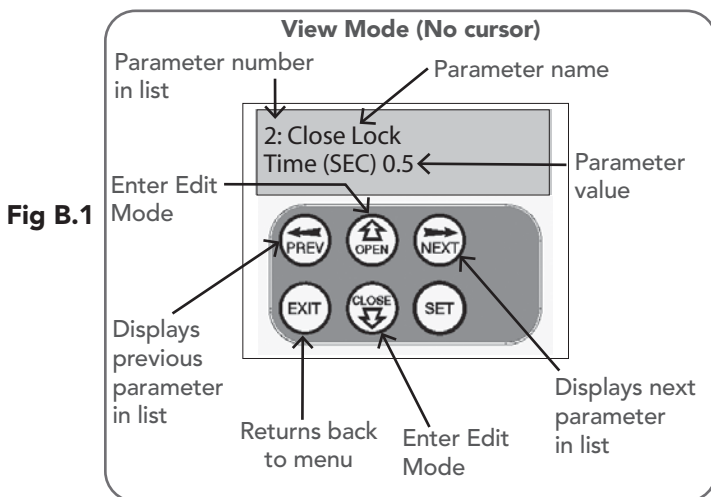

This section illustrates how to locate, view and adjust parameters.

### Locating parameters

Refer to Appendix A for Console Menu Structure. Locate the required parameter and note the MENU number. The example used in **(Fig. B.1)** displays "CLOSE LOCK TIME"

### Changing Setting

- Press NEXT/PREV to navigate to the required menu.
- Press SET to show the sub-menu.
- Press NEXT/PREV to go to the required sub-menu.
- Press OPEN/CLOSE to change parameter setting. Holding the button down causes the parameter's value to change rapidly. The longer the button is held the faster the value changes.
- Press SET to SAVE setting.

### Reload Default Setting

- Press NEXT/PREV buttons to display LOAD DEFAULT screen.
- Press SET to load the default value.

### Return To Menu

If the parameter values are not to be changed, press EXIT to return to sub menu. Press EXIT again to return to the MAIN SCREEN.

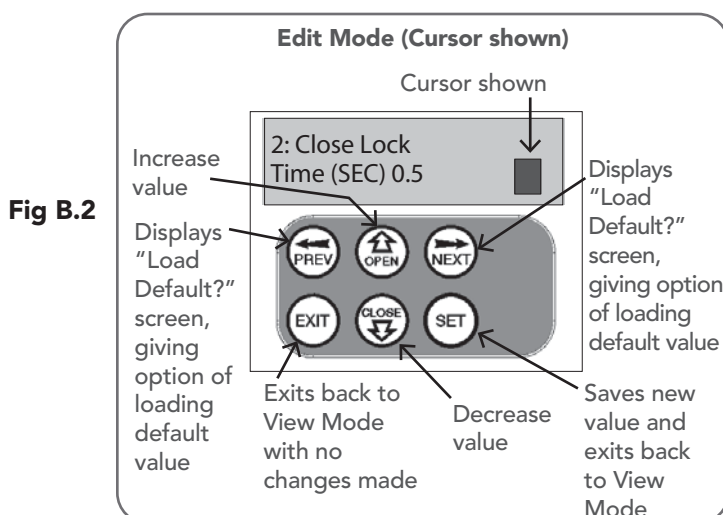

# Appendix

## C - Control Board Adjustments

The standard operation of the opener can be altered by editing various parameters. This section describes the parameters and the effect they have. Use the VIEWING AND EDITING PARAMETER PROCEDURE (Appendix B) to make changes.

### Menu 6. Motor settings

#### Motor speed

The motor settings adjust various aspects of the gate travel. When a single gate installation is used the SYNC DELAY TIMES and M2 settings are ignored. The default value for the CLOSE SYNC DELAY time is automatically calculated for LIMIT SWITCH/AMP TRAVEL installations. The value calculated is selected so that the delay between M2 and M1 reaching the close position is equal to the OPEN SYNC DELAY TIME. The MAX OVERRUN TIME is set to 0 for TIMED TRAVEL installations.

### Menu 7. Operating Modes

#### Menu 7.1 First (SB1) Safety Beam Type

Select what type of Safety Beam (2 WIRE or 3 WIRE). 2 WIRE is default.

#### Menu 7.2 Second (SB2) Safety Beam Type

Select what type of Safety Beam (2 WIRE or 3 WIRE). 2 WIRE is default.

#### Menu 7.3 First (SB1) Safety Beam Response Mode

The Safety Beams input can be configured to respond in one of eight modes.

- i. **Not Used**
- ii. **Close to Reverse** In this mode, the Safety Beam input has no effect when opening but will cause the gate to reverse if activated when closing.
- iii. **Close to Stop** In this mode, the Safety Beam input has no effect when opening but will stop the gate when closing.
- iv. **Open and Close to Stop** In this mode, all cycles are prevented from being completed or initiated when the Safety Beam input is active.
- v. **Open input** In this mode, open cycle is initiated when the Safety Beam is activated.
- vi. **Swipe input** In this mode, open cycle is initiated when the Safety Beam is activated.
- vii. **Close input** In this mode, close cycle is initiated when the Safety Beam is activated.
- viii. **Ped input** In this mode, ped cycle is initiated when the Safety Beam is activated.
- ix. **Disabled** In this mode, Safety Beam is disabled.

#### Menu 7.4 Second Safety Beam (SB2) Response Mode

Same as above menu 7.3

#### Menu 7.5 PED Input Function

If GPI or Fire Input is selected as PED then these inputs can be configured to a SWIPE type input for pedestrian access. This provides full functionality with the Safety Beam Triggered Pedestrian Auto-Close function.

#### Menu 7.6 Open (OPN) Input

(Activated by OPN terminal with N/O switch, by transmitter button with OPN function assigned or by console's UP button) Activating the OPN input will cause the gate to open. Holding the input will prevent closing.

#### Menu 7.7 Stop (STP) Input

(Activated by STP terminal with N/O switch, by transmitter button with STP function assigned or by console's EXIT button) Activating the STP input while the gate is moving will cause the gate to be stopped. If the STP terminal is held it will prevent the gate from being moved.

#### Menu 7.8 AUX Input

Is Default to Light, however can be changed to Motor Engaged.

#### Menu 7.9 Vacation Mode

Vacation mode can be turned on or off using this parameter. DCB-05V2 supports a Vacation mode where remote control access is disabled. The mode is activated by pressing a transmitter button with the VAC function assigned until the console displays that vacation mode is enabled (approx. 5 seconds). When activated any transmitter button which is assigned VAC will be ignored. To turn the Vacation mode off, simply press a transmitter button with the VAC function assigned (Only requires a brief activation). Vacation mode can also be turned on or off manually by editing the VACATION MODE parameter. DCB-05V2 can be instructed, via the pedestrian control feature, to partly open and provide pedestrian access but prevent vehicle access. This is achieved by partly opening the motor 1 gate leaf. If dual motors are used, motor 2's gate leaf is held closed. The partly open position of motor 1's gate leaf is initially set to a position halfway between open and closed. This initial position can be adjusted by the installer to any position within the gates travel range by selecting a pedestrian access travel time (from closed). The setting is accessed from "MENU 10.4 Set Pedestrian". The time is adjustable in 1 second steps

#### Menu 7.10 Remote Code

The controller supports the Remote Code Set feature. This parameter can be used to disable the feature for security or transmitter management reasons.

#### Menu 7.11 Battery / Solar Mode

The controller can be instructed to turn off the Battery Backup / Solar facilities so that the control board can be shut down without having to disconnect the Battery Backup / Solar system.

#### Menu 7.12 Password Protection

The password feature enables all parameters and configuration settings to be protected unless a password is entered. When this feature is turned on, the user is requested to enter the desired password to be used. The password protection feature has a time-out that expires after 60 seconds of inactivity. Alternatively, the user may log out manually by pressing exit when the main screen is displayed.

#### Menu 7.13 Transmitter Grouping

The transmitter store number display format can be changed to show a grouped format. When grouping is selected, instead of displaying the store location as a number between 1 and 511, it will display as ##\$ where ## is the group number and \$ is a character a,b,c,d,e,f,g or h which indicates the group member.

#### Menu 7.14 Output1 Mode

AUX output can be selected to be driven by:

- i. **LockDrive:** Lock output can be programmed for both hold and pulse mode. The operation of the lock can be programmed to activate prior to the gate and behave differently on open cycles to that on close cycle.
- ii. **LightDrive:** a light relay module can be connected on the console between V+ and OUT2 terminal which will turn the courtesy light on and off.
- iii. **3 Wire Safety Beam 0V:**
- iv. **Not Used**

# Appendix

## C - Control Board Adjustments

### Menu 7.15 Output2 Mode

AUX output can be selected to be driven by:

- i. **Lock Drive:** Lock output can be programmed for both hold and pulse mode. The operation of the lock can be programmed to activate prior to the gate and behave differently on open cycles to that on close cycle.
- ii. **Light Drive:** a light relay module can be connected on the console between V+ and OUT2 terminal which will turn the courtesy light on and off.
- iii. **3 Wire Safety Beam OV:**
- iv. **Not Used**

### Menu 7.16 Fault, Auto Reset

When selected, the controller will reset any fault automatically.

### Menu 7.17 Safety Beam Failure Emergency Close Mode (SBFEC)

When a safety beam prevents movement due to any reason other than a 'real' obstruction, the user can secure their property by pressing and holding a button on the remote control or OSC on the console. The button must be held active for more than five seconds to activate this mode and hold the button for the entire duration of close cycle.

# Appendix

## D- Diagnostic Tools

Fig D.1

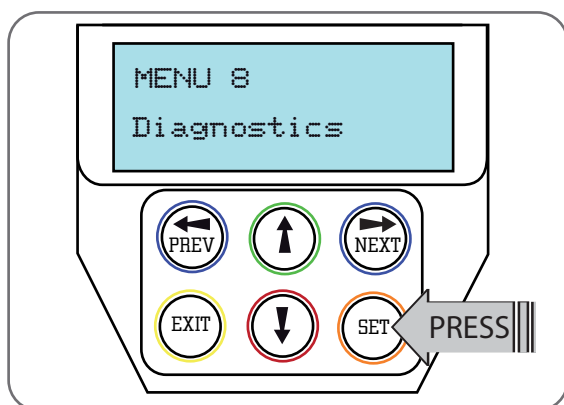

The controller provides several diagnostic tools from within the Diagnostics Menu (Menu 8). This section details the function of each tool and its use.

#### Navigating To Diagnostics Menu

- a. Press PREV to navigate to Menu 8 (**Fig. D.1**).
- b. Press SET to display the menu of available functions.
- c. Press PREV or NEXT to cycle through diagnostic tools.
- d. Press SET to select.

#### Menu 8.1 Test Inputs

This tool is used to view the state of the control inputs. When selected, a screen is displayed (**Fig. D.2**) which indicates the state of each input. If the name of the input is in upper case or number in the bracket, then the input is active. Conversely if the input is in lower case and [---] dash in the bracket, then the input is inactive. For normal operation, all inputs should be inactive. When finished, press EXIT. The example shows the status as OSC input is active.

Fig D.2

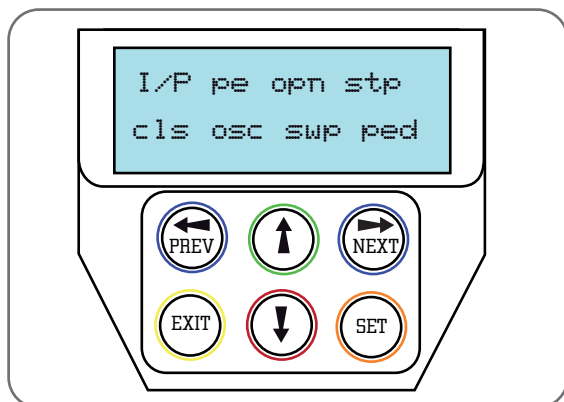

#### Menu 8.2 Test Transmitters (Tx'ers)

This tool is used to test receiver/transmitter functionality. When selected, a screen is displayed which prompts for a transmitter button to be pressed (**Fig. D.3**) and whether ID or serial numbers are to be displayed.

DCB-05V2 will then beep each time a transmission is received. If the transmitter button is stored in the DCB-05V2's memory and has a function assigned to it, a second screen will be displayed that shows the transmitter details along with the button pressed (**Fig. D.4**). The example shows the case where transmitter number 12 is activated by button 4. Note ID is selected for display.

Fig D.3

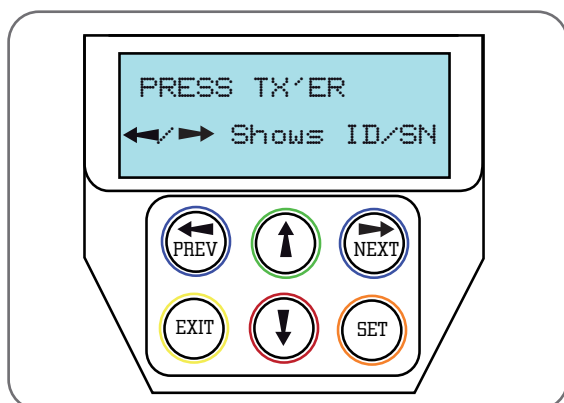



# Appendix

## D- Diagnostic Tools

### Menu 8.3 Display History

DCB-05V2 keeps a record of the last 64 events that have taken place. The events include the type of drive cycles executed, obstruction detection, various faults, power failures etc. When this tool is selected, the screen displays the last event that occurred (**Fig. D.5**). Press NEXT or PREV to view each event. The "EVENT#" field shows the sequence of the events, with (1) being the first and (64) being the last. The example shows that the last event was a close cycle which succeeded in closing the gate. When finished viewing the events, press EXIT.

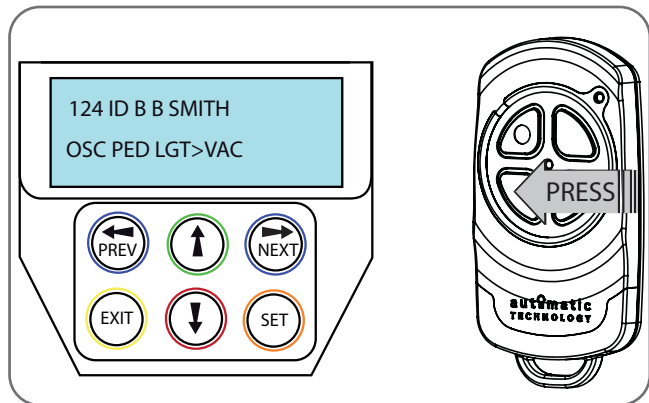

Fig D.4

### Menu 8.4 Memory Usage

This tool displays the number of transmitter store locations used and the number free.

### Menu 8.5 Service Counter

DCB-05V2 provides a periodic service counter which can be set to expire after a number of drive cycles. When expired, DCB-05V2 will beep at the beginning of each drive cycle and a message will be displayed on the MAIN SCREEN (**Fig. D.7**). This tool displays the current value of the service counter and allows the user to set its value using the normal parameter editing techniques (See PARAMETER VIEWING AND EDITING). If the service counter is not to be used, it can be set to the maximum number (60,000).

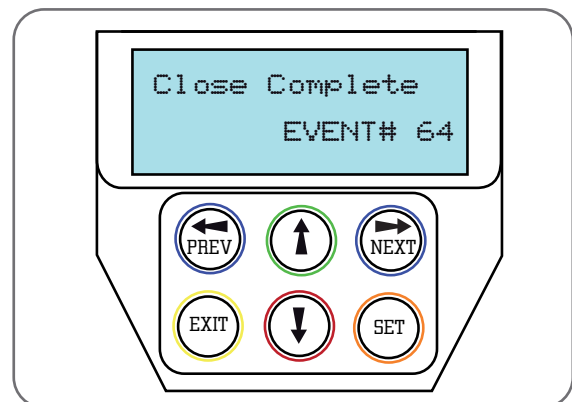

Fig D.5

### Menu 8.6 Event Counters

The opener keeps a count of number of times a particular event occurs. The list of event counters kept is shown below. When this tool is selected, the first event counter is shown (**Fig. D.8**). Press NEXT or PREV to step through the list. The example shows the OPEN CYCLE event counter with a value of 1234. When finished viewing press EXIT.

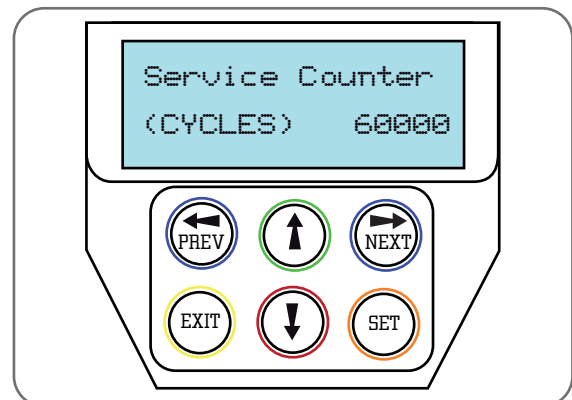

Fig D.7

- |                          |                           |
|--------------------------|---------------------------|
| 1: Open Cycles           | 2: Close Cycles           |
| 3: PED Cycles            | 4: Warranty Cycles        |
| 5: Setup Limits          | 6: Overlaps               |
| 7: M1 Open Obstructions  | 8: M2 Open Obstructions   |
| 9: M1 Close Obstructions | 10: M2 Close Obstructions |
| 11: M1 Open Overloads    | 12: M2 Open Overloads     |
| 13: M1 Close Overloads   | 14: M2 Close Overloads    |
| 15: M1 Volts Faults      | 16: M2 Volts Faults       |
| 17: M1 AMP Faults        | 18: M2 AMP Faults         |
| 19: Supply High Faults   | 20: Supply Low Faults     |
| 21: M1 AMP Trip          | 22: M2 AMP Trip           |
| 23: 3W Limit Faults      |                           |

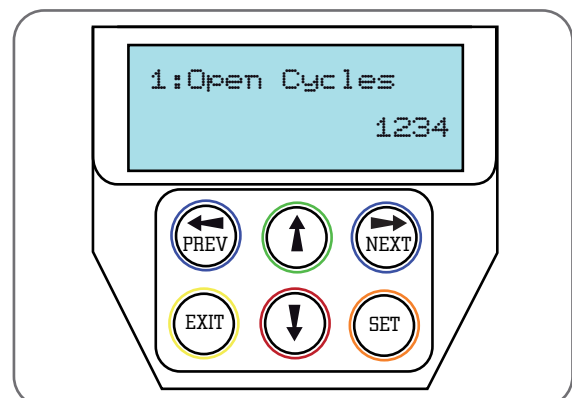

Fig D.8

# Appendix

## E - Memory Tools

The Memory Tools accessed from within Menu 9 are used to backup, restore or clear the controller. Once selected, the PREV or NEXT buttons can be used to view the Memory Tool options. To Execute the displayed option simply press SET.

### Menu 9.1 Clear Control

This option will clear the gate control memory and reload the factory set defaults for parameters such as the lock time, light time, auto-close times etc. It will also clear the travel limits.

### Menu 9.2 Clear Transmitters (Tx'ers)

This option will clear the transmitter storage memory.

# Appendix

## F- Transmitter Editing

Fig F.1

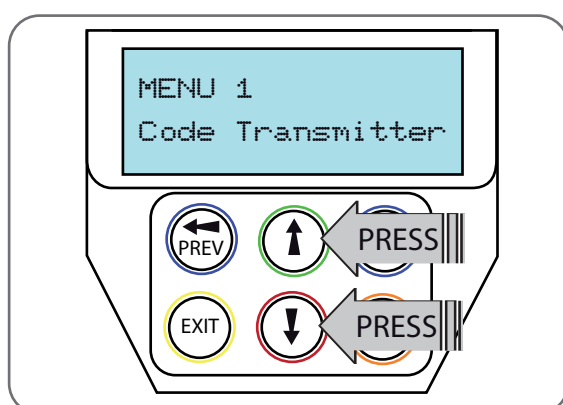

Navigating To "Edit Transmitter" Menu

- Press NEXT to navigate to Menu 1.
- Press SET to enter the transmitter edit procedure.
- Press NEXT to enter transmitter list and edit mode.

Editing Button Function Field

- Press NEXT or PREV to move the cursor to the left or right and between the top and bottom lines to select the desired field.
- Press UP or DOWN arrows to change the displayed value (**Fig. F.1**). The available functions are shown below. Selecting OFF will prevent the opener responding to that button.

#### Available functions

VAC (Vacation Mode)	LGT (Courtesy Light)
STP (Stop)	OPN (Open)
CLS (Close)	SWP (Swipe)
PED (Pedestrian access)	OSC (Open/Stop/Close)
OFF (No action)	

Fig F.2

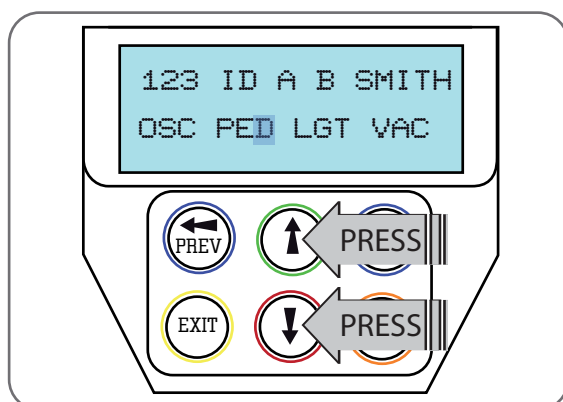

- Press SET to save changes or press NEXT or PREV to move to the next field. The example in (**Fig. F.2**) shows that PED is assigned to the transmitter button 2. The transmitter in the example is transmitter number 123 which has the ID label AB Smith.

**NOTE:** If all button functions are set to OFF, when SET is pressed, the opener will prompt to confirm if the transmitter is to be deleted. Press SET to delete or EXIT to continue editing.

Fig F.3

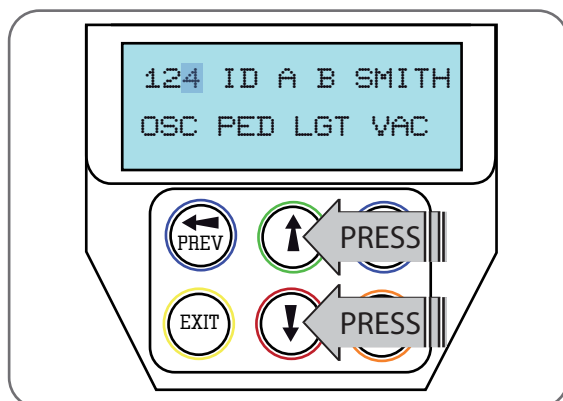

Editing The Store Location

This feature is only available when coding the first button of a new transmitter.

- Press NEXT or PREV to move the cursor over Store No. (**Fig. F.3**)
- Press UP or DOWN arrows to select new Store No.
- Press SET to Confirm or NEXT/PREV to move to the next field.

This is useful when managing transmitters using a scheme which ties the store location to the transmitter's owner.

# Appendix

## F- Transmitter Editing

### Selection Of ID or Serial Number Display

- Press NEXT to navigate to the Menu 1 "Code Transmitter".
- Press SET to enter the transmitter edit procedure.
- Press NEXT to enter transmitter list and edit mode.
- Press NEXT/PREV to move the cursor over the ID field.
- Press NEXT to reveal the Serial Number (**Fig. F.4**).

The serial number display is provided for additional means of identification. The transmitter in this example has serial number 123456789.

### Editing A Character Field

- Press NEXT or PREV to move select character.
- Press UP or DOWN arrows to scroll through and select a new character. (**Fig. F.5**)
- Press NEXT or PREV to move to the next character.
- Repeat step b.
- Press SET to record changes.

The second line of the display shows a list of available characters with the current value indicated at the cursor position.

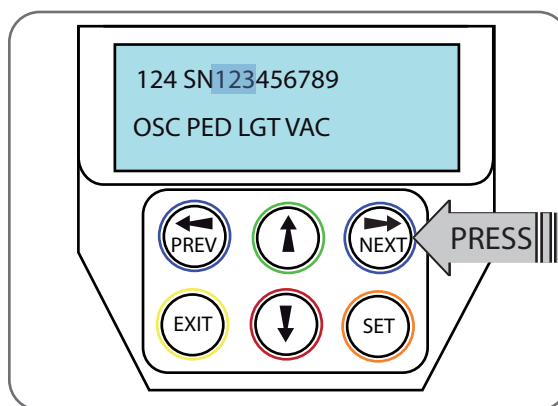

Fig F.4

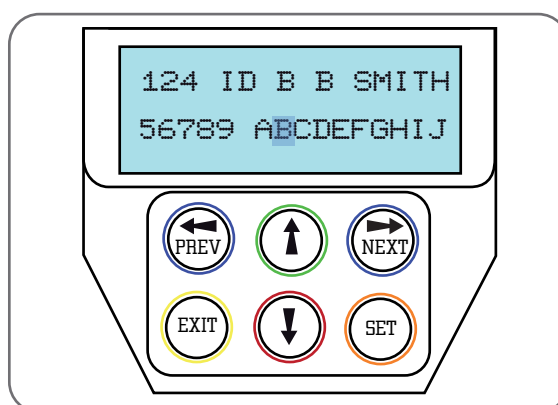

Fig F.5

# Appendix

## G- Transmitter Management

### Transmitter Listing Facility

DCB-05V2 provides a transmitter listing facility which enables the user to find a transmitter location within memory. Once located a stored transmitter can be replaced, deleted, edited, copied or, if the location is empty, a new transmitter can be coded.

### Method 1 - Go To The Start Of The List

#### Accessing The List Menu

- Press NEXT to navigate to Menu 1.
- Press SET to enter the transmitter edit procedure.
- Press NEXT to enter the transmitter list and edit mode.

### Method 2 - Use The Transmitter To Go Direct To The List

#### Accessing The List Menu

- Press NEXT to navigate to Menu 1.
- Press SET to enter the transmitter edit procedure.
- Press the transmitter once.
- Press NEXT to view the transmitter parameters (**Fig. G.1**). This method is used for quick navigation if the transmitter is available.

### Navigating The List

- Press the UP or DOWN arrows to navigate through the list.
- NOTE:** Holding a button down will step through the list faster.
- Press SET to display the menu of available functions.

### Selecting An Operation

- Press NEXT or PREV to cycle through the four menu options (**Fig G.2 over page**)
- Press EXIT to return to the list.
- Press SET to execute the menu's operation.

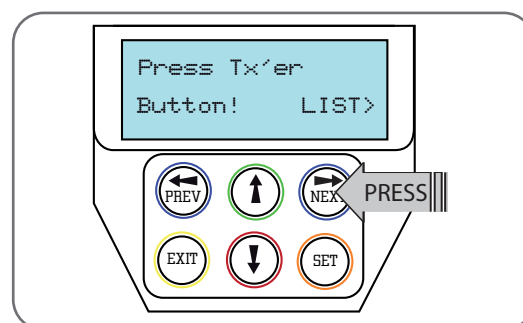

Fig G.1

**NOTE:** "VIEW" will not be shown if the transmitter is not stored. Once the list is displayed, it can be sorted by stored number, ID Label or Serial Number. Use the NEXT or PREV buttons to select the sorting method.

**NOTE:** When sorting by ID label or S/N, only stored transmitters locations are displayed.

# Appendix

## G- Transmitter Management

Menu Option	Operation
Code Operation (location empty)	If the code operation is selected on an empty transmitter location, the BASIC CODE TRANSMITTER PROCEDURE will be initiated with the transmitter being saved in the selected location. This is useful when managing transmitters using a scheme which ties the store location to the transmitter's owner.
Code Operation (location used)	If the code operation is selected for a location that already contains a transmitter, then the BASIC CODE TRANSMITTER PROCEDURE will be initiated and the new transmitter will replace the existing one. Note that the button functions and name of the existing transmitter will be transferred to the new transmitter. This procedure is of great convenience when replacing a lost transmitter.
Delete Operation	The delete operation is used to remove a transmitter from memory along with the name and button function settings.
Edit Operation	The edit operation displays the transmitter record for editing purposes. See TRANSMITTER EDIT PROCEDURE (Appendix F) for details.
Copy Operation	The copy operation is used to code multiple transmitters with the same button function as that of the selected transmitter. Once selected an abbreviated code set routine is initiated which repeats steps 2 & 3 of the BASIC CODE TRANSMITTER PROCEDURE for each transmitter to be coded. Coding is terminated by pressing the EXIT button.
Exiting The List	To exit the transmitter list, simply press EXIT to return to the Code menu.

Fig G.2

# Appendix

## H- AMP Travel (2 Wires Setup)

Fig H.1

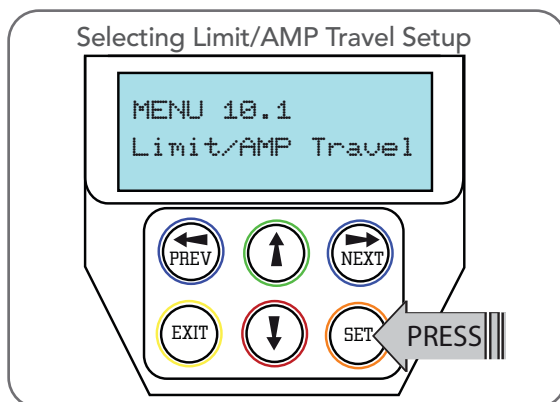

PLEASE NOTE, THE FOLLOWING INSTALLATIONS ARE FOR 2 WIRE SETUPS ONLY

### Selecting The Number Of Motors

- Press NEXT to navigate to Menu 10.1.
- The DCB-05V2 will now prompt for the number of motors connected to be entered.
- Use the UP or DOWN arrows to select the correct number and then press SET (**Fig. H.1**).
- Press EXIT.

### Navigating To "Limit/AMP Travel Menu"

- Press NEXT to navigate to Menu 10.
- Presee SET to locate Menu 10.1.
- Press SET again to start the limit setting procedure .
- DCB-05V2 will prompt you to confirm that the motor wiring is complete (**Fig. H.2**) and that the gate(s) are at fully open position and engaged.
- Press SET to confirm.
- DCB-05V2 will now automatically detect the type of drive unit used by the number of wires used. If the correct number of wires is displayed then press SET to continue otherwise press EXIT and check the wiring.
- DCB-05V2 will now automatically detect if one or two motor are connected. If the correct number is displayed then press SET to confirm. Otherwise press EXIT and check the wiring (**Fig. H.3**).

Fig H.2

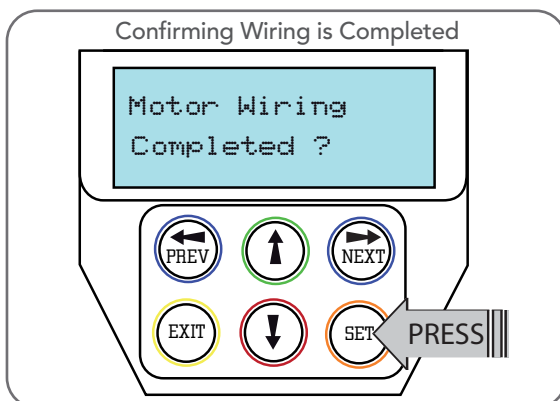

# Appendix

## H- AMP Travel (2 Wires Setup)

### Test and Adjust Stop Detection

For this type of installation the DCB-05V2 detects the travel limits by sensing a motor current trip when the mechanical stop is reached.

**NOTE:** If a dual gate installation is being used, complete steps for motor 2 and then motor 1.

- To Setup Limits follow the instructions on the LCD display.
- Open the gates fully and engage the motors.
- Using the UP and DOWN arrows drive the gate using one continuous movement stopping just before the mechanical stop.

**NOTE:** If the motor drives in the wrong direction (UP closes gate / DOWN opens gate) the motor wires need to be swapped over.

### Confirming Settings

When the settings have being adjusted correctly, drive the gate to the open stop.

- Press the SET Key
- In order to run automatic profiling the DCB-05V2 will prompt you to confirm the gate leaf is in the open position.
- Press SET to confirm or press EXIT to go back and drive the gate open (**Fig. H.4**).

### Automatic Profiling

After a brief pause DCB-05V2 will automatically close and open gate several times and learn the gates load and travel characteristics.



**WARNING: The gate will automatically close and open. Ensure that no persons or objects are in the gates path.**

When the setup is complete the MAIN SCREEN will be displayed with the gate shown to be OPEN.  
The Gate can now be used.

### Reprofiling Travel

- Reprofiling is a simplified way of re-learning the travel characteristic of a previously setup Limit Switch travel installation. Re-profiling can be used when the travel characteristics of the gate(s) change due to mechanical adjustments etc. To initiate a re-profile, simply locate "MENU 10.3 Reprofile Travel", press SET and follow the prompts. The gate(s) will start to move and re-calculate force margins. The gate(s) can move between the open and close limit positions up to two (2) times (depending on the position of the gate(s) and the power up condition).
- A single beep will be heard once the process is complete.
- Test the force again as per "Safety Obstruction Force Test" (Section 9.1 and 9.2)..

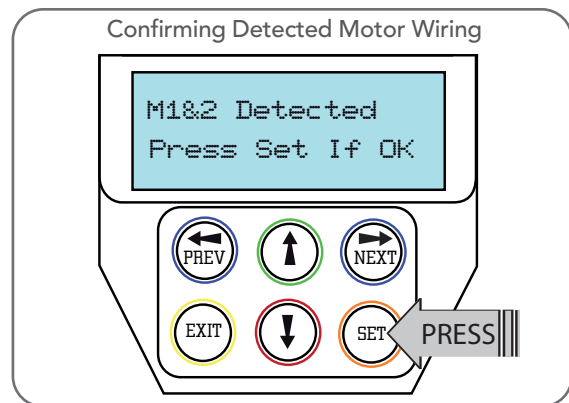

Fig H.3

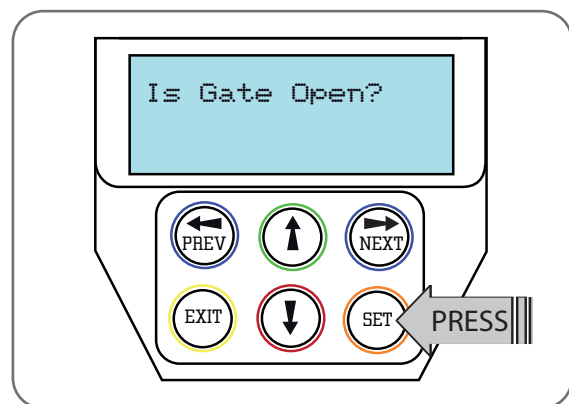

Fig H.4

# Appendix

## I - Time Travel 2 Wire Setup

This section shows how to set the travel times when using drive units with slip clutches etc. Two methods are available for setting up the travel times. The first allows the installer to drive the motor(s) so that the actual travel time can be recorded. The second allows exact times to be entered.

NOTE: The limit setting procedure can be aborted at any time by pressing EXIT.

### Navigating To "Timed Travel Menu"

- Press NEXT to navigate to Menu 10.
- Presee SET to locate Menu 10.2.
- Press SET again to start the the setup.
- Confirm that the motor wiring is complete. Press SET to continue.
- No current trip obstruction detection is available when using timed travel. Press SET if you accept this (**Fig. I.1**).
- Enter the number or motors by using the UP or DOWN key to select the correct number and then press SET.

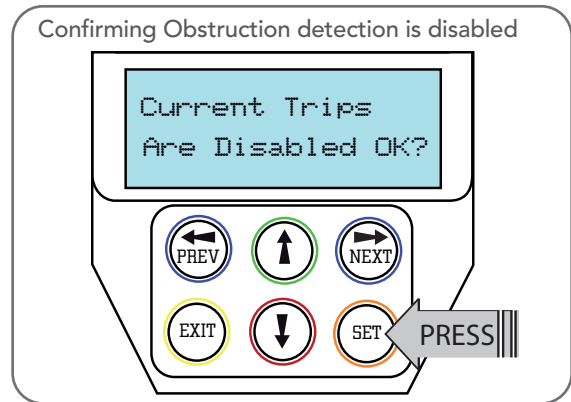

Fig I.1

### Selecting Setup Method

- DCB-05V2 will now prompt for the setup procedure to be selected. There are 2 methods (**Fig. I.2**);
  - DRIVE MOTORS = Press SET to continue
  - ENTER TIME PARAMETERS = Press EXIT to continue

### DRIVE MOTORS

#### Adjusting Gate Leaf Synchronising Delays.

(Dual gate installations only)

DCB-05V2 will prompt for you to edit the gate leaf synchronising delays. The settings are used to introduce a delay between when the motors start so that overlapping gates are opened and closed in the correct order.

- Press SET to access the gate leaf synchronising delay parameters
- Follow LCD display to edit delay.

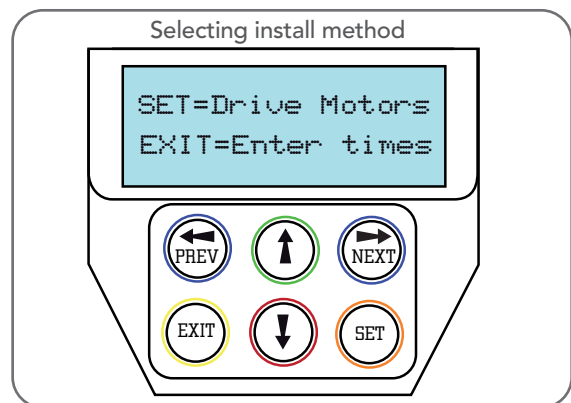

Fig I.2

### Confirming Gate Is Open

DCB-05 will now prompt for you to confirm that the gate is open.

- If the gate is open press SET and continue.
- If the gate is closed Press EXIT and DCB-05 will now prompt for the gate to be opened.
  - Press and Hold the UP key until the gate is open. When the UP key is released the motor(s) will stop and you will be asked if the gate is open.

**NOTE:** If the motor drives in the wrong direction the motor wiring needs to be swapped.

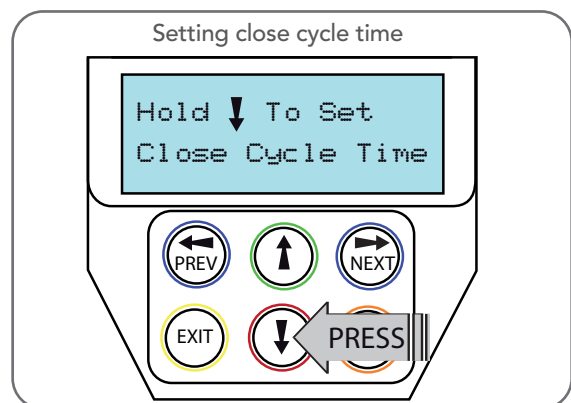

Fig I.3

### Setting Close Cycle Drive Time

To set the close cycle drive time press and hold the DOWN key until the gate is driven fully closed. (**Fig I.3**)

**NOTE:** If the motor drives in the wrong direction the motor wiring needs to be swapped.

### Setting Open Cycle Drive Time

To set the open cycle drive time press and hold the UP key until the gate is driven fully open.

### Confirming Settings

Press SET to confirm or EXIT to restart from Confirming gate is open.

Once the setting have been SET and the main screen is displayed, the gate is ready for use.

### ENTER TIME PARAMETERS

When the ENTER TIMES method is selected a list of parameters is provided to configure the gates travel. The parameters provided are listed below in **Fig I.4** with a brief description.

Parameter	Description
M1 Normal Open Time	Sets Open drive time for M1
M1 Normal Close Time	Sets Close drive time for M1
* M2 Normal Open Time	Sets Open drive time for M2
* M2 Normal Close Time	Sets Close drive time for M2
* Close Sync Delay	Sets Delay before M1 is started on closed cycles
* Open Sync Delay	Sets Delay before M2 is started on open cycle

\* Only used for dual gate installations. Once the parameter values have be set press EXIT and the main screen is displayed, the gate is ready for use.

Fig I.4



---

© June 2015 Automatic Technology (Australia) Pty Ltd. All rights reserved. TrioCode™128 is a trademark of Automatic Technology (Australia) Pty Ltd. No part of this document may be reproduced without prior permission. In an ongoing commitment to product quality we reserve the right to change specification without notice. E&OE.

automatic  
TECHNOLOGY

**Automatic Technology (Australia) Pty Ltd**

ABN 11 007 125 368

6-8 Fiveways Boulevard  
Keysborough, Victoria, 3173, Australia

P 1300 133 944

+61 3 9791 0200 (International Enquiries Only)

E [sales@automatictechnology.com.au](mailto:sales@automatictechnology.com.au)

[www.automatictechnology.com.au](http://www.automatictechnology.com.au)

SMART  
SIMPLE  
SECURE