

# Smart Phone Control Kit

## Smart Hub Installation Instructions

### Gate Openers

NETWORK SMART HUB KIT - ORDER NO. 14879		
ITEM	DESCRIPTION	QTY
1	WIRELESS HUB100 WT B&D	1
2	POWER SUPPLY AU 240V	1
3	WALL BRACKET HUB100	1
4	PLASTIC WALL PLUG 6.9 X 25	2
5	SELF TAPPING SCREW 6 X 25	2
6	NETWORK TRANSCEIVER MODULE	1
7	HARNESS 4 CORE 275 ASSY	1
8	ANTENNA	1

This device must be connected to power at all times. **DO NOT** disconnect power after setup.



**This device allows for operation of the gate when not in line-of-sight of the gate and opener.**

**The gate may operate unexpectedly**, therefore do not allow anything to stay in or near the path of the gate. When the gate is not operating automatically, watch the gate when it is moving and keep people away until the gate is completely opened or closed. **Contact with the moving gate can cause serious personal injury or damage to property.**



It is our strong recommendation that your opener be fitted with **SAFETY BEAMS**. Safety Beams detect any obstructions in the gates path and override automatic operation if one presents. These must be installed as in accordance with AS/NZS 60335-2-95:2012.

This is in addition to regular professional servicing, and monthly obstruction tests as detailed in your opener's Home Owners Manual.

## Important Safety Instructions



### WARNING!

- DO NOT attempt to disassemble, repair or modify the product. This will invalidate the warranty.
- Do not allow children to play with the Smart Hub or your smart phone if the ATA phone app has been installed.



### ELECTROCUTION!

- Keep the device away from water and other liquids. In the event that water or other liquids enter the device, power off the product immediately and clean the device.
- To reduce the risk of fire or electric shock, do not expose this device to rain or moisture. The device should not be exposed to dripping or splashing.
- DO NOT remove the cover as there are no user-serviceable parts inside.



### CAUTION:

Fall from ladder

Burns

- Ensure ladder is the correct type for job.
- Ensure ladder is on flat ground.
- Ensure user has 3 points of contact while on ladder.
- DO NOT handle damaged or leaking batteries
- The battery backup kit contains sealed lead-acid batteries that must be disposed of properly at the end of their useful life.

# Smart Hub Set Up

## Mounting the Hub

- a. Determine whether you are going to wall mount the hub.
  - i. If hub is to be placed on bench, simply connect to power supply (2), turn on and proceed to installing the Transceiver.
  - ii. If hub is to be wall mounted follow steps below.
- b. To wall mount - Use wall bracket (3) as template to mark where to drill holes. Pre-drill holes.
  - i. For plaster walls - insert (2) two Plastic wall plugs (4) into holes, place wall bracket over holes and affix with (2) two self tapping screws (5).
  - ii. For brick walls - place wall bracket (3) over holes and affix with (2) two self tapping screws (5).
- c. Slide the hub over the bracket.
- d. Connect the power supply (2) and turn on.

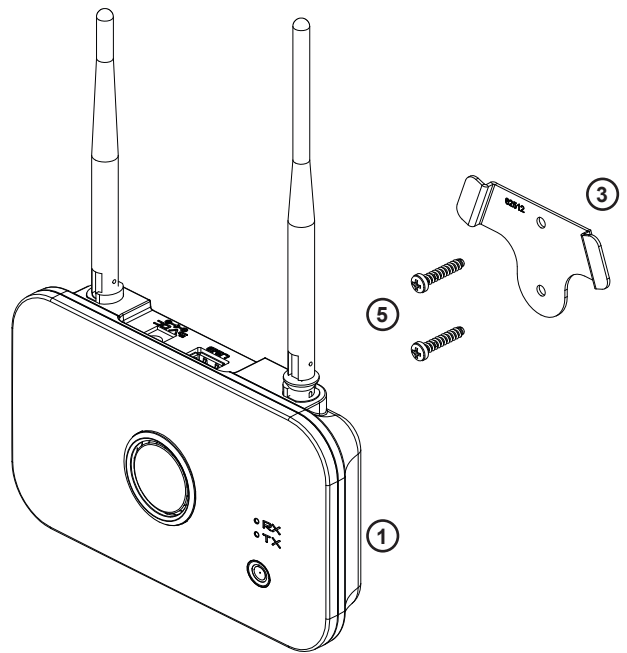

**This device must be connected to power at all times. DO NOT disconnect power after setup.**

## Mounting the Transceiver to the Opener

- a. Disconnect the power supply to the opener and open the main cover.
- b. Connect the harness (7) to NETWORK on the control board, before attaching to the network transceiver module (6) as shown.
- c. Thread the antenna cable (8) through the unit as shown and connect to the network transceiver module.
  - :DCB-05 requires additional hole in cover. Secure with glan provided.
  - :NES500/800 the antenna cable enters the unit through the bottom plate.
- d. Place the network transceiver inside the opener / controller.
- e. Close cover.
- f. Download the ATA App and follow the instructions in the App to setup new smart hub.
- g. Use a programmed remote and run the door through a few cycles which will update the unit with the details of the transceiver module.

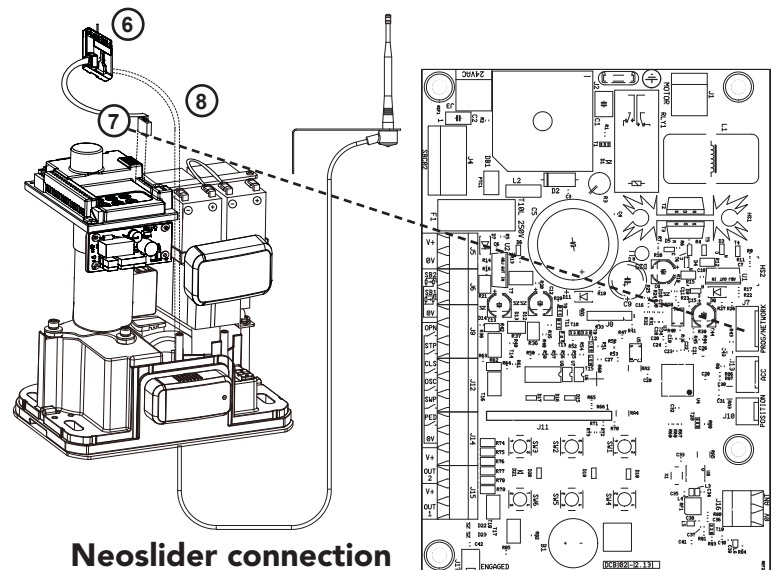
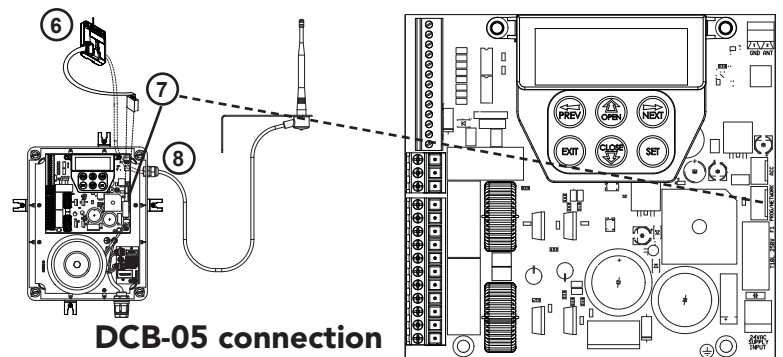

# Warranty

WARRANTY	
ACCESSORIES	1 year

This warranty is to be read in conjunction with the owner's copy of the opener installation instruction.