

The 771ANZ Photoelectric Beam System is designed to increase the safety and functionality of your garage door or gate motor.

The system uses an invisible beam across the garage door or gate opening. If an obstruction breaks the light beam while the door/gate is closing, the door/gate will stop and reverse to full open position.

The units may be installed on either side of the door so long as the sun never shines directly into the receiving eye lens. **NOTE:** The brackets must be connected and fastened so that the sending and receiving eyes face each other.

The Beams *must* be securely fastened to a solid surface such as a stud wall for garage doors or bollard or wall for gates.

The invisible light beam path must be unobstructed. Ensure no part of the door (or door tracks, springs, hinges, rollers or other hardware) interrupts the beam while the door or gate is closing.

Suitable for Gate Motors and Garage Door Application

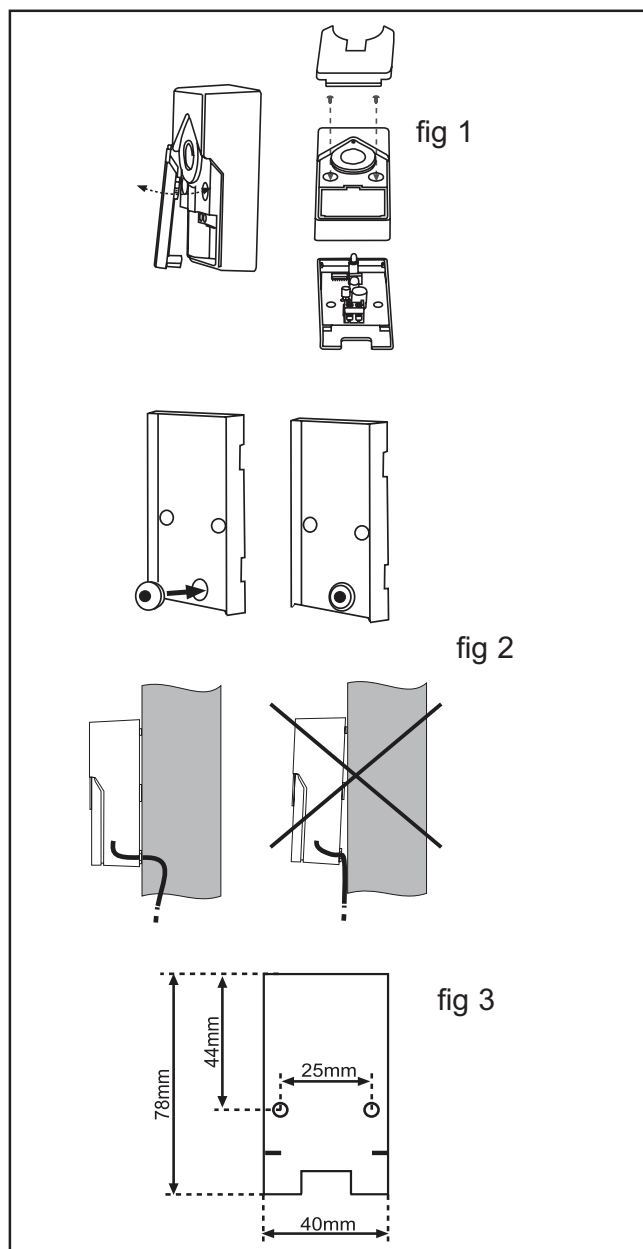
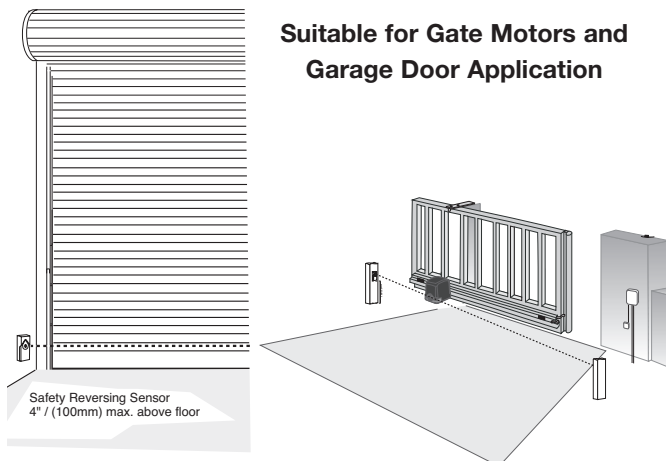

**WARNING!**

Review all safety warnings outlined in your door operator owner's manual. Ensure that the door/gate and all there fixtures and fittings are in good condition.

### ASSEMBLY PROCEDURES

- Run two wires (not provided) from the sending eye and the recieving eye back to your garage door motor or gate control board.
- Ensure the cable exit point in you wall or bollard is exactly the same on both sides.
- Remove the cover plate from the base of the beam as illustrated in fig 1.
- Insert the grommet (provided) as illustrated in fig 2.
- Mark out the fastening positions as illustrated in fig 3, take not of the cable exit to ensure the cable enters through the grommets.
- Terminate cables to positive and negative terminals and take note of the polarity before connecting to the garage door motor or gate motor as outlined of pages 2 and 3.

**WARNING!**

To protect small children, install the Protector System™ no higher than (100mm) above the floor for garage door. For gates consult your owners manual for requirements. Disconnect power to the garage door opener before installing the 771ANZ

# Wiring Connections Merlin Professional

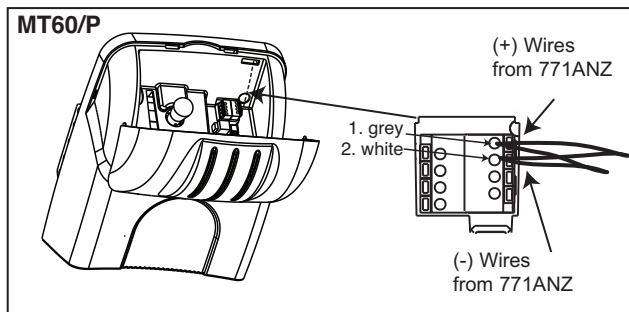

## MT60/P connections

Open the lens cover on the front of the unit to access the connection terminals. Strip all wires back about 10mm twist the two (-) wires together, then twist the the two (+) wires together. Trim the twisted wires to approximately 6mm. Use a small screwdriver or pen to hold down the spring terminals, insert the (+) wires into the grey terminal (1), then terminate the (-) (only) wires into the white terminal (2).

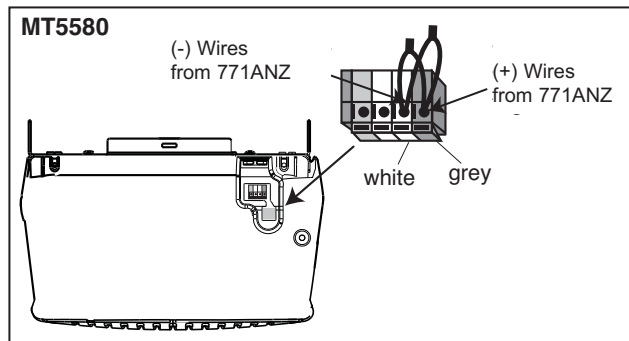

## MT5580 (all models) connection

Locate the connection terminals on the back of the unit. Strip all wires back about 10mm, twist the two (-) wires together, then twist the two (+) wires together. Trim the twisted wires to approximately 6mm. Use a small screwdriver or pen to hold down the spring terminals, insert the (+) wires into the grey terminal, then terminate the (-) wires into the white terminal.

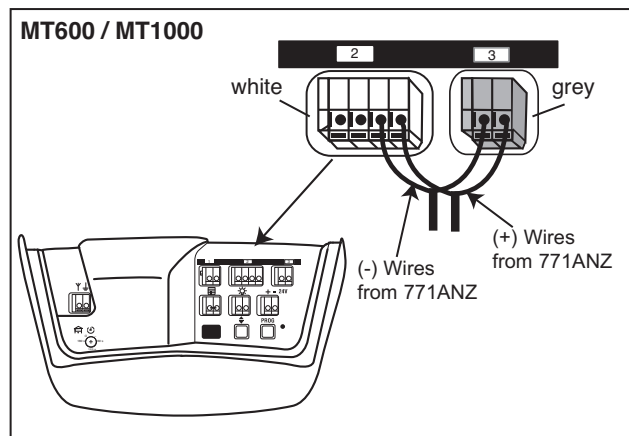

## MT600 / MT1000 connections

Locate the terminals on the back of the unit. Strip all wires back about 10mm, twist the two (-) wires together, then twist the two (+) wires together. the twisted wires to approximately 6mm. Use a small screwdriver or pen to hold down the spring terminals, insert the (+) wires into the grey terminal (3), then terminate the (-) wires into the white terminal (2).

NOTE: Optional connections: Connect the (-) wires and (+) wires into separate terminal on the back of the unit as illustrated above. This may be required if larger diameter cable extensions have been used to extend wiring.

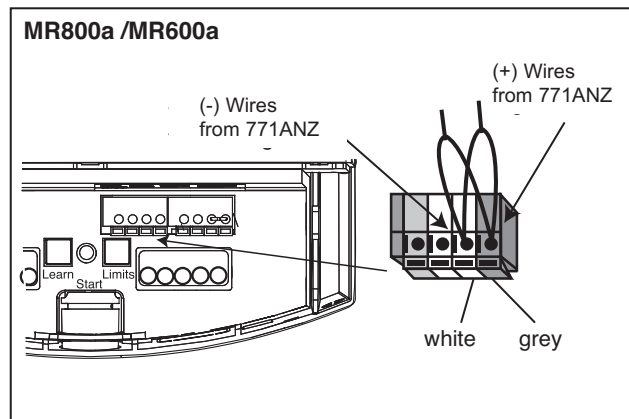

## MR600a / MR800a connections

Gently lift the diffuser on the base of the motor to access the terminals. Strip all wires back about 10mm, twist the two (-) wires together, then twist the two (+) wires together. Trim the twisted wires to approximately 6mm. Use a small screwdriver or pen to hold down the spring terminals, insert the (+) wires into the grey terminal, then terminate the (-) wires into the white terminal.

## Setting Autoclose MR600A, MR800A/ MT1000 (ONLY)

Auto Close NOTE:

Ensure that the trim pot is set to 0s when terminating cables. Beams must be uninterrupted for up to five minutes after turning on to initialise. (The Trim pot should not be adjusted during this 5 minute initialising period).

Note: After the beams are initialised they are fail safe i.e. if they removed, the motor will not close until the beams are re(-)installed.



WARNING: Door may operate unexpectedly, therefore do not allow anything to stay in the path of the door.

# Wiring Connections GRIFCO CG3800/R

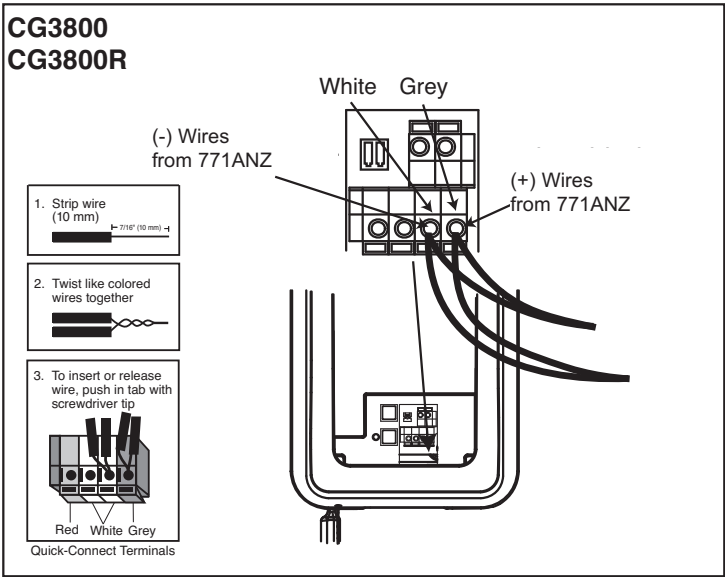

## CG3800/R connections

Gently lift the cover flap at the base of the motor to access the terminals. Strip all wires back about 10mm then twist the two (-) wires together, then twist the two (+) wires together.. Trim the twisted wires to approximately 6mm. Use a small screwdriver or pen to hold down the spring terminals, insert the (+) wires into the grey terminal, then terminate the (-) wires into the white terminal.

# Wiring Connections Merlin Professional Gate Motors

## CB22 Control Board Merlin Professional sliding gate motors.

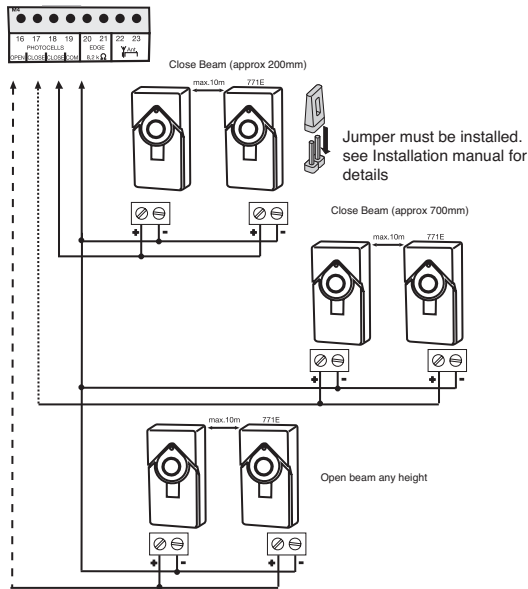

## CB12 Control Board Merlin Professional Swing Gate..

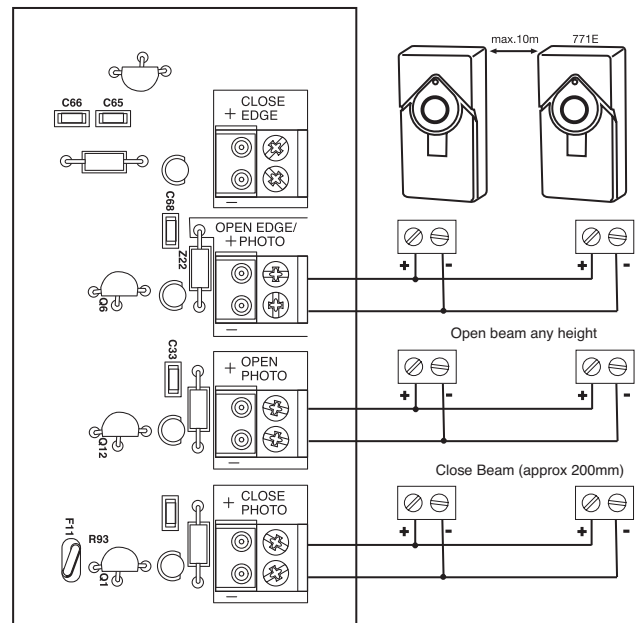

## Aligning and Testing the beams

- Plug in the opener. If your opener has the Multi-Function Door Control, make sure the Lock Feature is off. Red indicator lights in both the sending and receiving eyes will glow if wiring connections and alignment are correct. If the indicator lights are blinking (and the invisible light beam path is not obstructed), alignment is required.
- Loosen the receiving eye wing nut to allow slight rotation of unit. Adjust sensor vertically and/or horizontally until the red indicator light glows.
- When indicator lights are glowing in both units, tighten the wing nut in the receiving eye unit.

## TEST THE 771ANZ Safety Beams

- Press the remote control push button to open the door.
- Place an object large enough to obstruct the sensor beam in the path of the door.
- Press the remote control push button to close the door.  
*The door will not move more than 40mm.*

**The door opener will not close from a remote control if the indicator light in either sensor is *blinking* (alerting you to the fact that the sensor is misaligned or obstructed).**

You can operate the door opener by disconnecting the safety reversing sensor.

***Professional service is required if the opener closes the door when the safety beam is obstructed.***

### TROUBLE SHOOTING

1. If the *sending eye* or *receiving eye* indicator light does not glow after installation, check for:
  - Electric power to the opener.
  - A short in the wiring circuit. These can occur under staples or at screw terminal connections.
  - Incorrect wiring between sensors and opener.
  - An open circuit, (wire break).
  - Lock switch on Multi-Function Door Control Panel is activated. Deactivate.
2. If both sensors are blinking, realign or remove obstruction.
3. Once an infrared sensor has been installed the motor will only operate whilst it is installed correctly.
4. **If the IR sensors are damaged and cannot be repaired:**
  - **For residential doors**, the motor can be closed using a hard wired wall switch if installed.
  - **Rollers door motors**, MR series may be closed using the activation button on the base of the rolling door motor.
  - **Sectional door motors**, MT series you will need to RESET the BEAM INPUT.

**For ALL Gate Motors**, contact your local service technician.

### RESETTING THE BEAM INPUT (Merlin Professional Model only).

**Note: Chamberlain beams are fail safe for your safety, this should only be performed when there is no other means of closing the door. Beams should be serviced or replaced as soon as practical to ensure the safe operation of your motor**

To reset the beam input:

- \* Remove all PE beam wires from the motor.
- \* Turn power off for 2 seconds
- \* Turn power on for 2 seconds
- \* Turn power off for 2 seconds

Turn the power back on and test your motor, it should open and close using the remote control.

**Once the door is operational perform THE SAFE REVERSAL TEST immediately.**



## WARNING

*Failure to test and adjust the safety reverse system may result in serious injury or death from a closing door. Repeat this test once a month and adjust as needed.*

### TEST THE SAFETY REVERSE SYSTEM

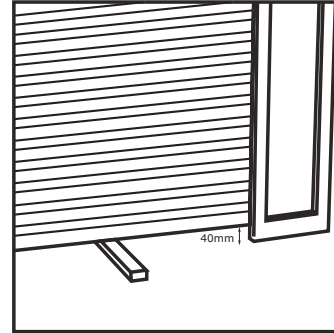

#### TEST: (Garage Doors ONLY)

- Place a (40mm) obstacle laid flat on the floor, centred under the door.
- Operate the door in the down direction. The door **must** reverse on striking the obstruction.

#### ADJUSTMENT:

If the door *stops* on the obstruction, it is not travelling far enough in the down direction.

**Consult your owners manual for instruction. Additional copies of all manuals are available from our web site [www.chamberlainanz.com](http://www.chamberlainanz.com).**

- Increase the DOWN limit by turning the DOWN limit.
- Repeat the test.

**On a sectional door, make sure limit adjustments do not force the door arm beyond a straight up and down position.**

- When the door reverses on the (40mm) obstacle, remove the obstruction and run the opener through 3 or 4 complete travel cycles to test adjustment.

***If the door will not reverse after repeated adjustment attempts, call for professional door service.***

Chamberlain Australia Pty Ltd  
PO Box 1446  
Lane Cove NSW 1595

Chamberlain New Zealand Ltd  
P.O. Box 100221  
North Shore 0745  
[www.chamberlainanz.com](http://www.chamberlainanz.com)

