

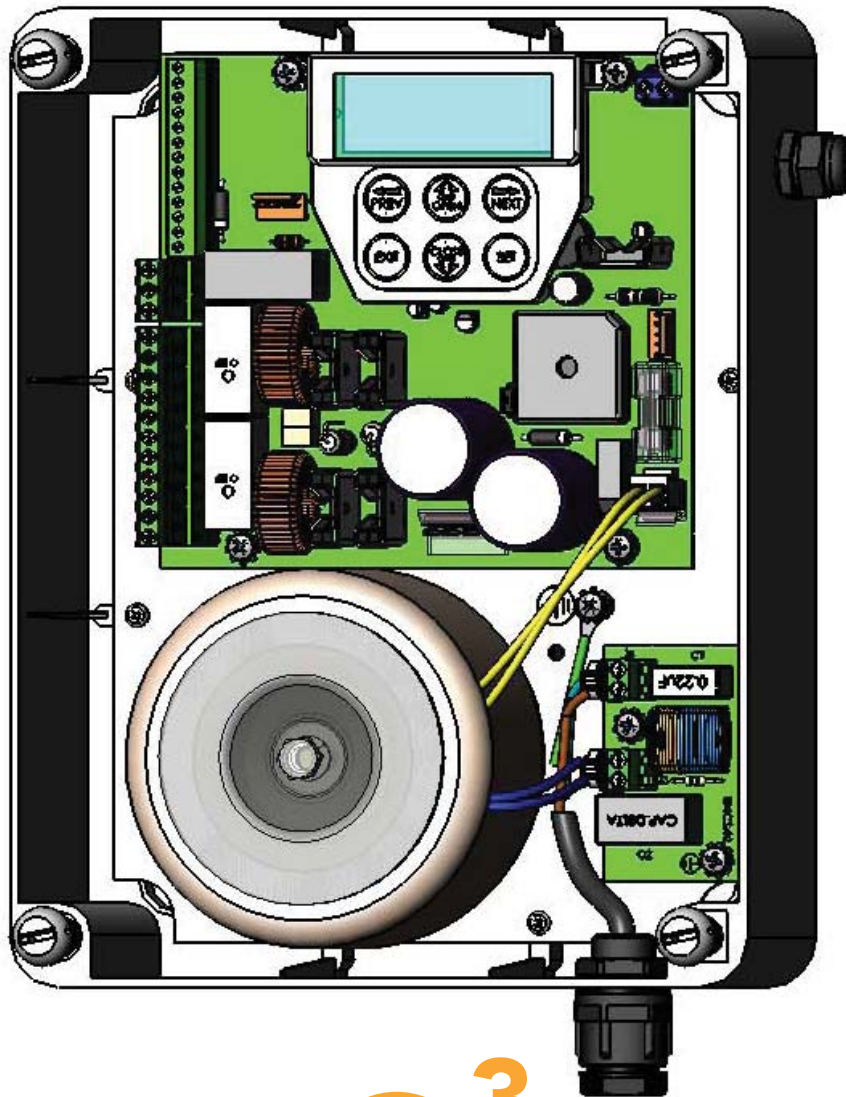

Dual Gate Controller

24 Volt Gate Control System DCB-05



Featuring **TrioCode™** Technology

automatic
TECHNOLOGY

smart | simple | secure



WARNING: It is vital for the safety of persons to follow all instructions. Failure to comply with the installation instructions and the safety warnings may result in serious personal injury and/or property and remote control opener damage. Please save these instructions for future reference.

Automatic Technology Australia Pty Ltd to the extent that such may be lawfully excluded hereby expressly disclaims all conditions or warranties, statutory or otherwise which may be implied by laws as conditions or warranties of purchase of an Automatic Technology Australia Pty Ltd Gate Controller and Automatic Technology Australia Pty Ltd hereby further expressly excludes all or any liability for any injury, damage, cost, expense or claim whatsoever suffered by any person as a result whether directly or indirectly from failure to install the Automatic Technology Australia Gate Controller in accordance with these installation instructions.



Dual gate controller

24 volt gate control system DCB-05

Important safety instructions	4		
Features	6		
Control board layout	8		
Menu structure	10		
Initial electrical installation	11		
Powering up drive unit	12		
Setting travel limits	12		
Standard Operating Modes	17		
Control board adjustments	19		
Menu 2 current trips	19		
Menu 3 Auto-close times	20		
Menu 4 Lock times	21		
Menu 5 Light times	21		
Menu 6 Motor settings	21		
Menu 7 Operating modes	22	Menu 8.3 Display history	31
Viewing and editing parameters	24	Menu 8.4 Memory usage	31
Transmitter Overview	25	Menu 8.5 Service counter	32
Coding transmitter	25	Menu 8.6 Counters	32
Transmitter editing	26	Memory tools (menu 9)	33
Transmitter management	28	Menu 9.1 Clr control	33
Code operation (location empty)	29	Menu 9.2 Clr tx'ers	33
Code operation (location used)	29	Menu 9.3 Backup tx'ers	33
Delete operation	29	Menu 9.4 Restore tx'ers	33
Edit operation	29	Menu 9.5 Import labels	33
Copy operation	29	Setting pedestrian position	34
Remote code set procedure	30	Accessories installation	35
Diagnostic tools (menu 8)	31	Specifications	37
Menu 8.1 Test inputs	31	Notes and record	38
Menu 8.2 Test tx'ers	31	Warranty and exclusion of liability	39





Important safety instructions

WARNING: It is vital for the safety of persons to follow all instructions. Failure to comply with the following Safety Rules may result in serious personal injury and/or property damage.



FOR ADDITIONAL SAFETY protection we strongly recommend the fitting of a Photo Electric (PE) Beam. In most countries PE Beams are mandatory on all gates fitted with automatic openers. For a small additional outlay Automatic Technology recommends that Photo Electric Beams be installed with the automatic opener ensuring additional safety and peace of mind.

DO NOT operate the gate opener unless the gate is in full view and free from objects such as cars and children/people. Make sure that the gate has finished moving before entering or leaving the driveway.

DO NOT operate the gate opener when children/people are near the gate. Children must be supervised near the gate at all times when the gate opener is in use. **Serious personal injury** and/or property damage can result from failure to follow this warning.

DO NOT allow children to operate the gate opener. **Serious personal injury** and/or property damage can result from failure to follow this warning.

Make sure that the **safety obstruction detection** system is working correctly, and is **tested** every month. Test as per the Installation Instructions Manual. Adjust if necessary and recheck. Failure to follow this rule could result in **serious personal injury** and/or property damage. This test must be repeated at regular intervals and the necessary adjustments made as required.

DO NOT disengage the gate opener to manual operation with children/people or any other objects including motor vehicle within the gateway.

If using a key switch or keypad or any device that can operate the gate opener, make sure it is out of reach of children and that the gateway is in full view at all times.

If the power supply cord is damaged, it **must** be replaced by an Automatic Technology service agent or suitably qualified person.

Make sure that remote controls are kept out of reach of children.



Important safety instructions

Please read this instruction manual fully before attempting to install or use the Dual Gate Controller. Failure to comply with the installation instructions may result in serious injury and/or property damage.

The Dual Gate Controller should not be immersed in water or sprayed directly by a hose or other water carrying device.

The gate(s) must be in good working order. Faulty gates must be repaired by a qualified technician prior to gate controller installation.

Connect the gate opener to a properly **earthed** general purpose 240V mains power outlet installed by a qualified electrical contractor.

Disconnect the power cord from mains power before making any repairs or removing covers. Only **experienced** service personnel should remove covers from the gate opener.

Keep hands and loose clothing **clear** of the gate at all times.

When using Auto-Close mode a **photo electric beam** must be fitted correctly and tested for operation at regular intervals. **Extreme caution** is recommended when using Auto-Close mode. **All safety rules** above must be followed.

In order for the gate controller to **sense** an object obstructing the gateway, some **force** must be exerted on the object. As a result the object, gate and/or person may suffer **damage** or **injury**.

Make sure that the gate is fully open before driving into or out of the driveway.

The gate controller is not intended for use by young children or infirm persons without adequate supervision. Children should be supervised to ensure that they do not play with the remote transmitters or the opener.





Features

Thank you for purchasing the automatic Dual Gate Controller from Automatic Technology. Designed for residential 24 volt swing and sliding gates by our world renowned team of engineers, this unit will give years of smart, simple and secure operation. Listed below are some of the many features.

Dual leaf gate

The Dual Gate Controller is able to control a single or dual leaf 24 volt swing or sliding gates .

Operation

To activate the gate simply press a button on the transmitter, keypad or use one of the other optional control devices. During an open or close cycle the gate can be stopped by pressing the button while it is in motion. The next actuation will move the gate in the opposite direction.

Operator console

The Dual Gate Controller features a LCD display operator console which simplifies installation, adjustments and status indication. Features include editing transmitter storage and names, setting parameters, selecting specialised operating modes and performing system diagnostics.

TrioCode™ Code Hopping Technology

Every time a TrioCode™ transmitter is used a new security code is randomly generated from over 4.29 billion possibilities. This greatly enhances the security of the system and makes "code grabbing" a thing of the past

These transmitters also overcome interference issues by simultaneously sending a signal over three different frequencies. Even if two of the three signals are jammed, the system will still work.

Security code store

The Dual Gate Controller uses revolutionary technology to securely store up to thirty (30) transmitters in its memory with the ability to assign 11 character name to each.

Various types of drive units supported

The controller can be used with gate drive units that use micro-switches, mechanical stops or slip clutches. In addition to this, the micro-switch type drive units can be wired using 3 or 5 wires.





Transmitter Management Flexibility

Whenever a large number of transmitters are used, managing those transmitters effectively is of great importance. The Dual Gate Controller provides many features which enhance transmitter management. Transmitters can be listed by store location, group number, serial number or I.D. Label. Tools are available which allow transmitters to be Replaced, Deleted and Edited. A quick transmitter code set feature is provided which allows the button functions of an existing transmitter to be copied to all transmitters to be coded. This feature allows many transmitters to be coded without the need for the installer to touch any console buttons during the coding process. When all transmitters are coded, a transmitter storage report can be generated which can be easily transferred to a P.C for record keeping. Access logging can also be implemented by enabling the generation of a transmitter activity report each time the receiver is triggered. During installation a handheld transmitter can be used to set gate travel limits, allowing the installer to closely monitor the gate's position and stop points instead of having to be within arms reach of the console.

Ease of installation

During installation the controller will automatically detect the wiring type and the number of motors connected. In addition the installer is guided through the steps of installation by first adjusting the travel limits (under motor power). This can be done via the console keypad or via a hand held transmitter (this allows the installer to closely observe and control the gates movement from any position rather than having to be within arms reach of the console). Once the limits have been adjusted, the controller will automatically learn the travel characteristic of each gate.

Password protection

All operating parameters and transmitter storage can be protected from being changed by unauthorised personnel by an optional password protection feature.

Status indication

The status of the Gate Controller can be determined at any time by observing the screen of the console. When the MAIN SCREEN is displayed, the current position of the gate or the result of the last movement can be viewed. The display will also show the count down progress of the Auto-Close timers. Any active input will also be displayed along with the state of various features such as periodic service, vacation mode, etc.

Control of lock and lights

The incorporated controller has two programmable outputs which can be selected to operate an electric lock and warning or courtesy lights. The timing of these outputs can be adjusted to suit your needs. In addition a button on a remote control can be coded to operate the Light output.

Smart Solar™ and Battery Backup Compatibility

The Dual Gate Controller can be fitted with optional Smart Solar™ or Battery Backup kit to provide operation during power outages or at unpowered sites.





Control board layout

- 01 PE V+ is used to power photo electric beam.
- 02 PE In for photo electric beam for safety
- 03 PE (v-) is used to supply (-) volt to photo electric beam.
- 04 Aux control input
- 05 OPN Programmable N/O or N/C input terminal
- 06 STP Programmable N/O or N/C input terminal
- 07 CLS N/O input terminal
- 08 OSC N/O input terminal
- 09 SWP N/O input terminal
- 10 PED N/O input terminal
- 11 COM terminal for input terminals 1 to 8
- 12 OUTPUT 2 (optional relay module coil drive)
- 13 OUTPUT 2 (optional relay module coil drive)
- 14 OUTPUT 1 N/C relay contact
- 15 OUTPUT 1 COM relay contact
- 16 OUTPUT 1 N/O relay contact
- 17 MOTOR 2 terminal 1
- 18 MOTOR 2 terminal 2
- 19 MOTOR 2 close limit switch input terminal
- 20 MOTOR 2 open limit switch input terminal
- 21 COM terminal for Terminals 16,17,19 & 20.
- 22 MOTOR 1 close limit switch input terminal
- 23 MOTOR 1 open limit switch input terminal
- 24 MOTOR 1 terminal 1
- 25 MOTOR 1 terminal 2
- 26 24VDC (+) output for powering accessories
- 27 24VDC (-) output for powering accessories
- 28 Standby battery / solar charger connector
- 29 24VAC power input (from transformer)
- 30 10 amp fuse
- 31 Programmer Input
- 32 Console keypad
- 33 Console display (LCD)
- 34 Antenna connector





Control board layout

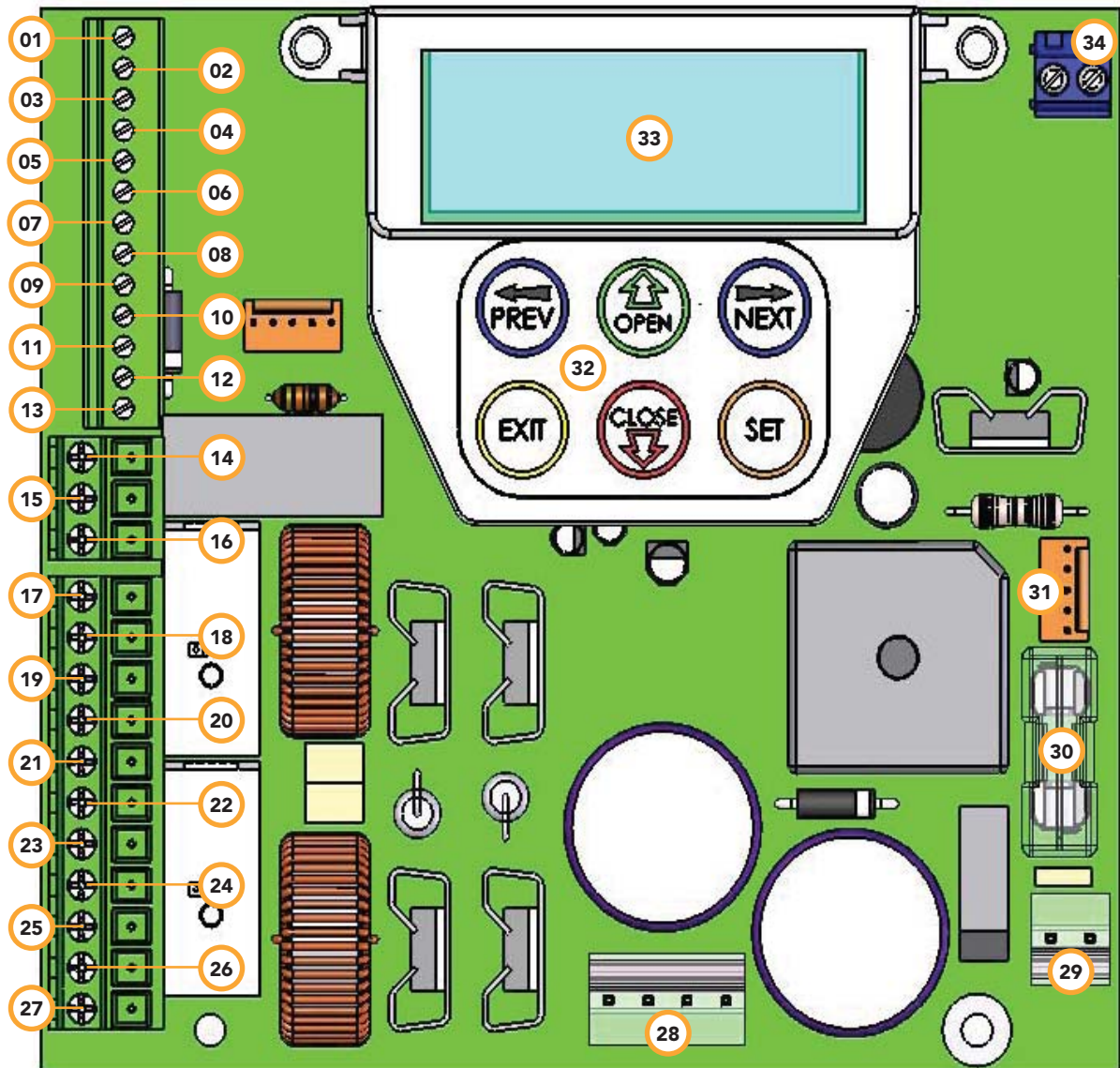
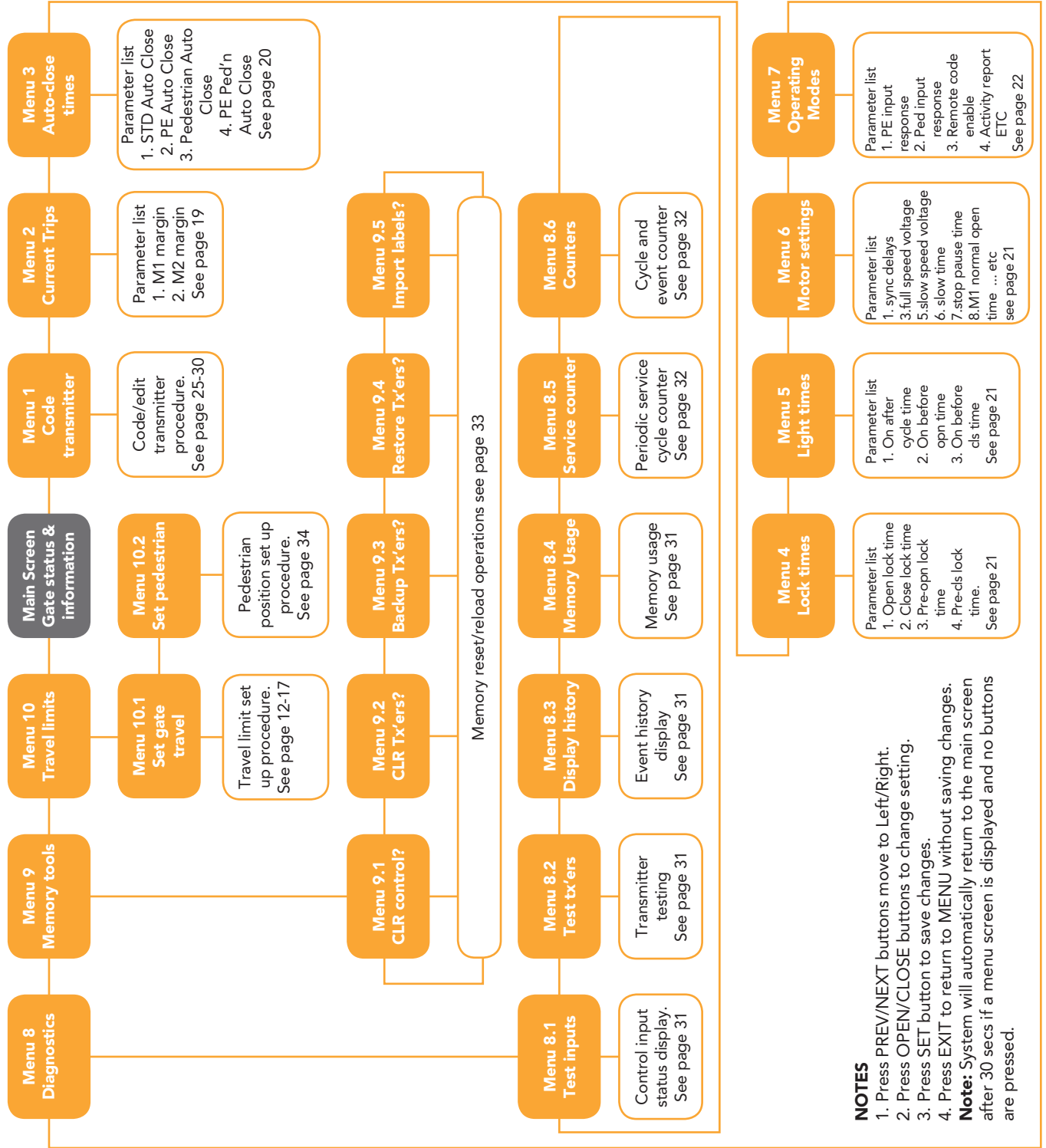

fig 01





Menu structure



NOTES

1. Press PREV/NEXT buttons move to Left/Right.
 2. Press OPEN/CLOSE buttons to change setting.
 3. Press SET button to save changes.
 4. Press EXIT to return to MENU without saving changes.
- Note:** System will automatically return to the main screen after 30 secs if a menu screen is displayed and no buttons are pressed.





Initial electrical installation



CAUTION: Cables which have a green/yellow coloured insulation are for earthing purposes only. Never use these cables for any other purpose.

Step 1. Wiring motors and limit switches

The Dual Gate Controller can be connected to the gate drive units in one of several ways. The diagrams (Fig. 2 to Fig. 4) show the various wiring methods used for different drive unit types. Select the appropriate method for your drive unit.

Note "non-motor current carrying limit-switch" type drive units can be connected using the standard 5 wire connections or a special 3 wire method that uses a single limit switch sense wire and two diodes. If two drive units are used, repeat the wiring for the second motor using the MOTOR 2 terminals.

Note the drive unit connected to the MOTOR 1 terminals will open first and will be used for pedestrian access.

The motor travel direction can be reversed by swapping the motor connections. An opportunity to confirm the correct motor polarity is provided during the limit setup procedure.

Step 2. Installing antenna

Mount the antenna at or above the height of the gate or fence (whichever is higher) for optimal reception. Do not cut the coaxial cable.

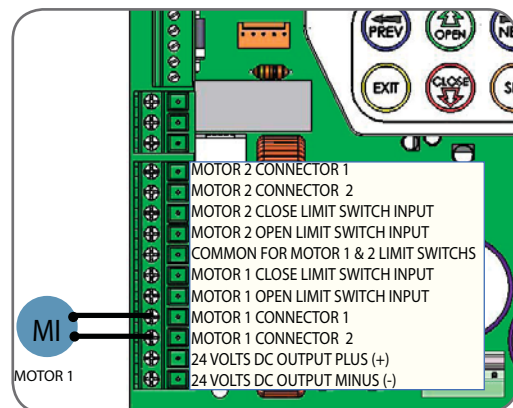
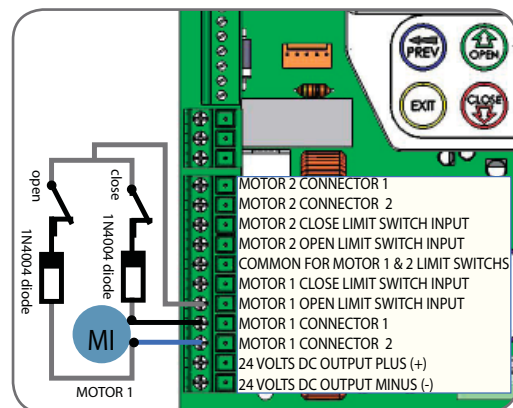
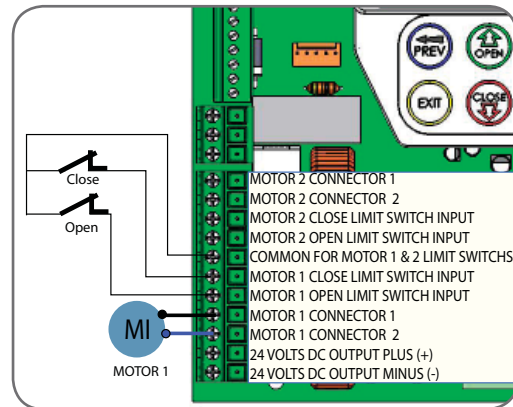



Powering up the controller

fig 05

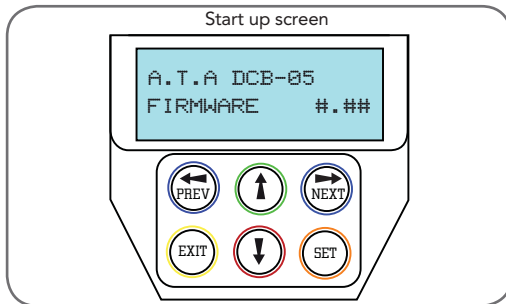

PLEASE NOTE - Before plugging the gate control system in, check the power cord for damage and ensure it cannot become entangled in any moving parts

After checking the initial wiring, apply power to the Dual Gate Controller. The controller will go through a startup sequence displaying the STARTUP SCREEN which indicates the controller type and firmware version **Fig. 05**. After a short delay the MAIN SCREEN will be displayed. If this is the first time the controller has been used, the MAIN SCREEN should indicate that the limits are not set **Fig. 06**. If the display shows that some input is active then rectify the situation before proceeding. If a default setting is to be changed it should be done now before setting the travel limits.

fig 06

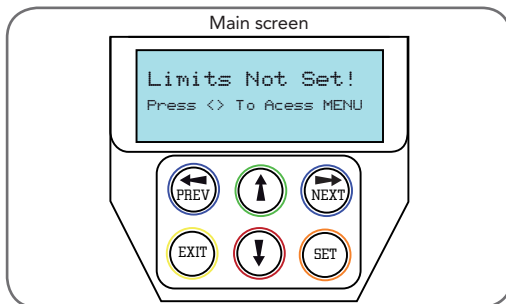

Setting travel limits

fig 07

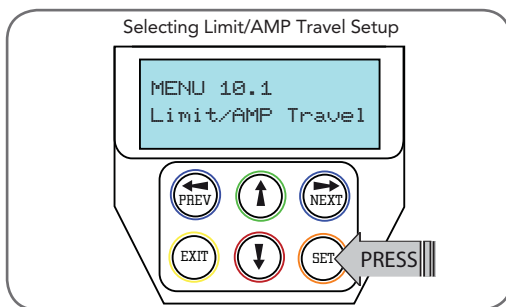

Dual Gate Controller can be used with drive units that use different methods to stop at the end of their travel. The types supported are:

A) Limit switch. Open and close limit switches indicate to the controller when the travel limit is reached.

B) AMP trip limits. Travel limits are detected by and an increase in motor current as mechanical stops are reached.

C) Timing. The motor is driven for a preset time. When the travel limit is reached a clutch incorporated into the drive unit allows the motor to keep turning for the remaining preset running time.

fig 08

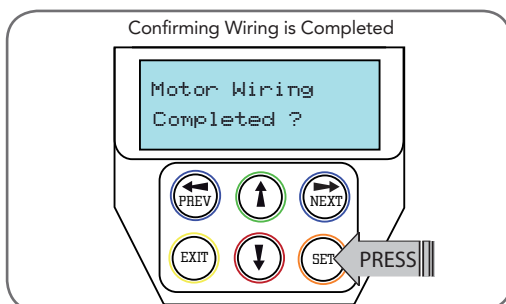

Step 1. Navigating To "Limit/amp Travel Menu"

To navigate to the Menu 10.1 from the main screen simply press PREV to display MENU 10, followed by SET to display MENU 10.1. Press SET again to start the limit setting procedure **Fig. 07**.





Setting travel limits (cont.)

Step 2. Confirming Ready To Start

The Dual Gate Controller will prompt you to confirm that the motor wiring is complete **Fig. 08** and that the gate(s) are in a halfway position and engaged. Press SET to confirm **Fig. 09**

Step 3. Confirming Correct Wiring Detected

The controller will now automatically detect the type of drive unit used by the number of wires used. If the correct number of wires is displayed **Fig. 10** then press SET to continue otherwise press EXIT and check the wiring. Continue From Step 4a page 14 For 2 Wire (Amp Travel) Setup.

Step 4. Confirming Motors Detected.

The controller will now automatically detect if one or two motor are connected. If the correct number is displayed then press SET to confirm. Otherwise press EXIT and check the wiring **Fig. 11**.

Step 5. Adjusting Close Limit(S)

The controller will now prompt for the motor(s) to be driven to the desired close limit and for the limit switches to be adjusted so that the motor stops at the desired position. The motor can be driven using the UP and DOWN buttons on the console keypad or Button 1 and 4 of a transmitter. After making adjustments to the limit switch positions always re-approach the limit at full speed by driving the motor open a short distance and then driving it close again. When the close limit has been adjusted press SET to continue **Fig. 12**.

Note: If the motor drives in the wrong direction (UP closes gate / DOWN opens gate) the motor wires need to be swapped.

Step 6. Adjusting Open Limit(S)

The controller will now prompt for the motor(s) to be driven to the desired open limit and for the limit switches to be adjusted so that the motor stops at the desired position. The motor can be driven using the UP and DOWN buttons on the console keypad or Button 1 and 4 of a transmitter. After making adjustments to the limit switch positions always re-approach the limit at full speed by driving the motor close a short distance and then driving it open again. When the open limit has been adjusted, press SET **Fig. 13**.

Step 7. Automatic Profiling

After a brief pause the controller will automatically close and open gate several times and learn the gates load and travel characteristics. When the setup is complete the MAIN SCREEN will be displayed with the gate shown to be OPEN. The Gate can now be used.

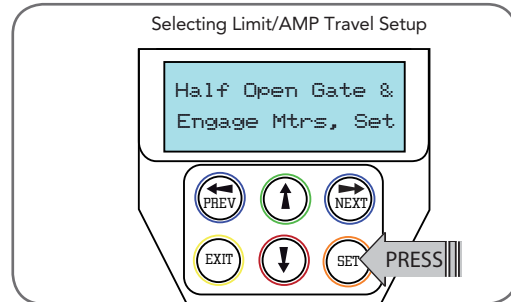

fig 09

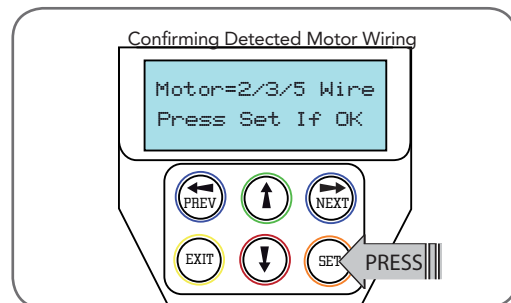

fig 10

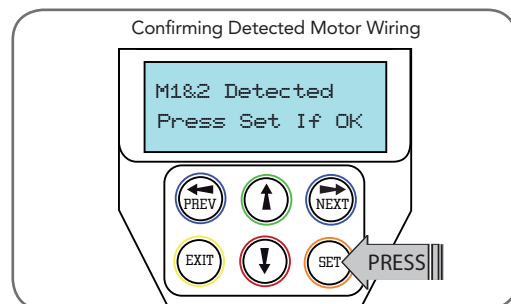

fig 11

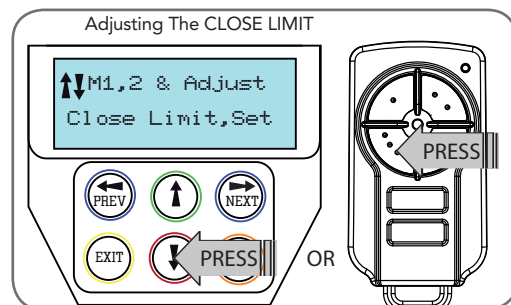

fig 12

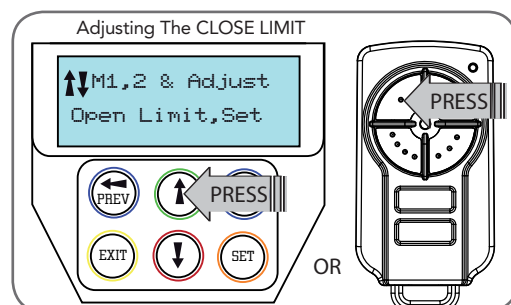

fig 13





Amp travel setup

fig 14

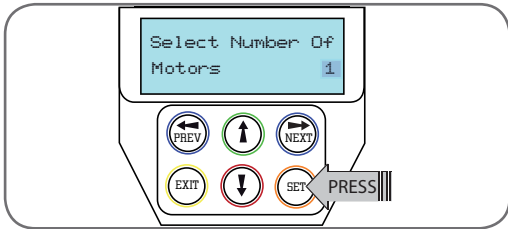

Step 4a. Selecting The Number Of Motors

The controller will now prompt for the number of motors connected to be entered. Use the UP or DOWN key to select the correct number and then press SET Fig. 14.

fig 15

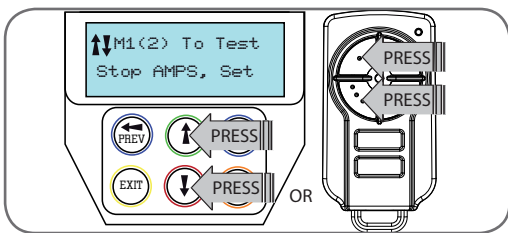

Step 5a. Test And Adjust Stop Detection Current Trip Levels

Note: If a dual gate installation is being used, steps 5A and 6A will be undertaken for motor 2 and then motor 1.

For this type of installation the controller detects the travel limits by sensing a motor current trip when the mechanical stop is reached. In this step, the stop detection current trip levels for each motor are tested and adjustments made to obtain the optimum level. A high value results in undue force, while a low value will result in the gate stopping midway due to variations in friction etc. Using the Up / DOWN keys drive the motor into the close and open stops and adjust the stop current trip levels. The motor should be driven into each mechanical stop at full speed until the controller senses a current trip and stops the motor Fig. 15.

fig 16

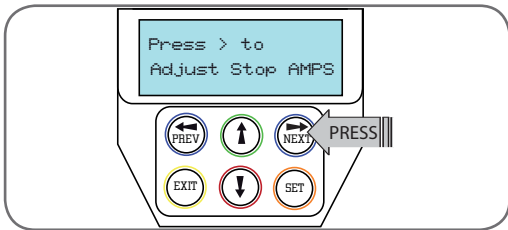

Note: If the motor drives in the wrong direction (UP closes gate / DOWN opens gate) the motor wires need to be swapped over.

The trip current for each direction can be viewed and adjusted by pressing the NEXT key on the keypad. See PARAMETER VIEW AND EDIT for adjustment procedure Fig. 16 - 17.

fig 17

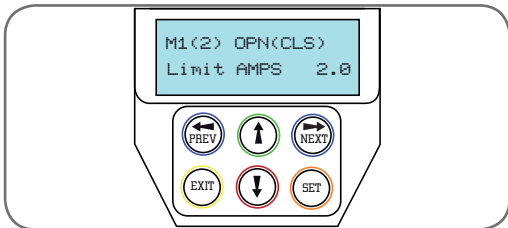

Step 6a. Confirming Settings

When the settings have been adjusted correctly, drive the gate to the open stop and then press the SET Key. As step 7A requires the gate to be open, the controller will prompt you to confirm the gate leaf is in the open position. Press SET to confirm or press EXIT to go back and drive the gate open Fig. 19.

fig 18

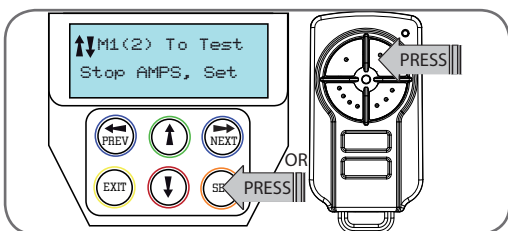

Step 7a. Automatic Profiling

After a brief pause the controller will automatically close and open gate several times and learn the gates load and travel characteristics. When the setup is complete the MAIN SCREEN will be displayed with the gate shown to be OPEN. The Gate can now be used.

fig 19

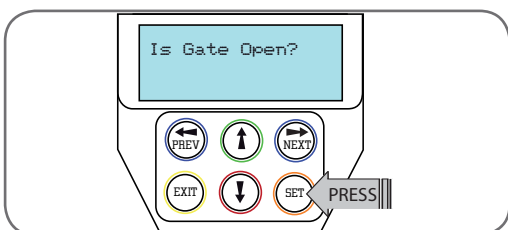

Re-profiling Travel

Re-profiling is a simplified way of re-learning the travel characteristics of a previously setup Limit Switch/AMP travel installation. Re-profiling can be used when the travel limits of a gate are altered or when the travel characteristics of the gate change due to mechanical adjustments etc. To initiate a re-profile simply locate "MENU 10.3 Re-profile Travel" and press SET then follow the prompts. The re-profile feature will also be automatically started when a control parameter is altered which affects the gates travel. Re-profile is not available for TIMED TRAVEL installations.





Timed travel setup

This section shows how to set the travel times when using drive units with slip clutches etc. Two methods are available for setting up the travel times. The first allows the installer to drive the motor(s) so that the actual travel time can be recorded. The second allows exact times to be entered. Note: The limit setting procedure can be aborted at any time by pressing EXIT.

Step 1. Navigating To "Timed Travel Menu"

To navigate to the Menu 10.2 from the main screen simply press PREV, SET then NEXT. Press SET to start the setup **Fig. 20**.

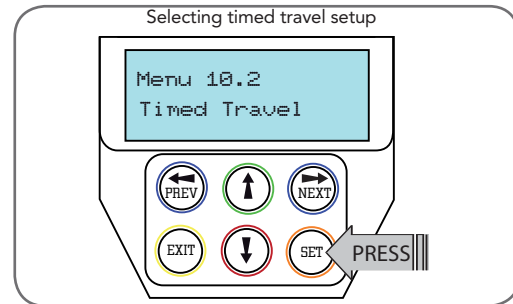

fig 20

Step 2. Confirming Ready To Start

The Dual Gate Controller will prompt you to confirm that the motor wiring is complete. Press SET to continue **Fig. 21**.

The controller will now prompt you to confirm that you understand that no current trip obstruction detection is available when using timed travel. Press SET if you accept this **Fig. 22**.

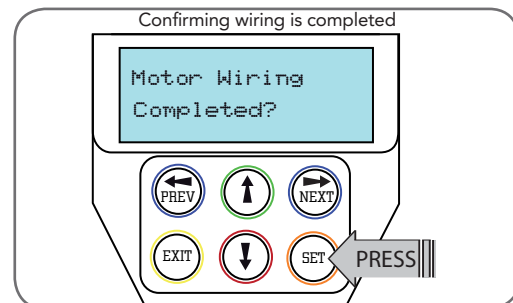

fig 21

Step 3. Selecting The Number Of Motors

The controller will now prompt for the number of motors to be entered. Use the UP or DOWN key to select the correct number and then press SET **Fig. 23**.

Step 4. Selecting Setup Method

The controller will now prompt for the setup procedure to be selected. Press SET to set the travel times by actually driving the motor(s) or press EXIT to enter

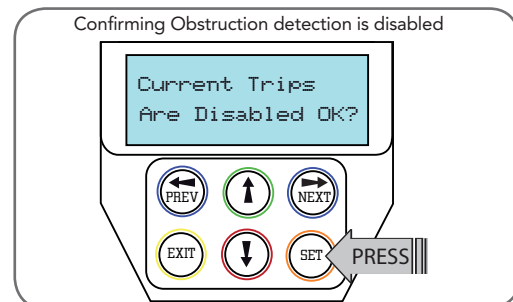

fig 22

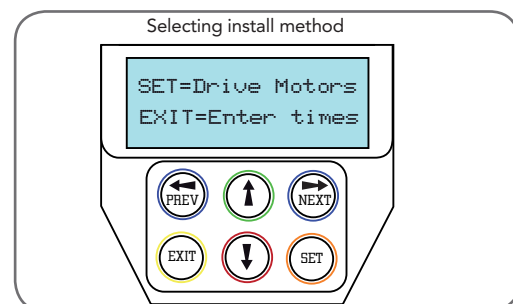
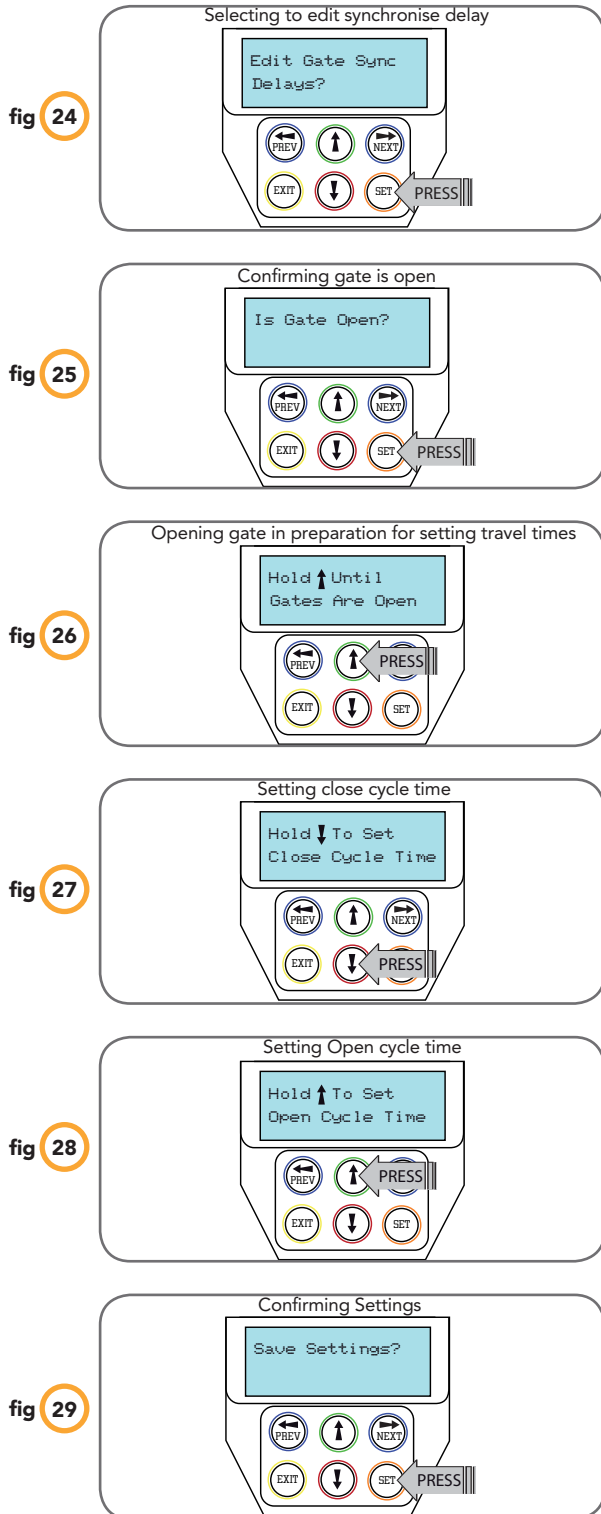

fig 23





Setting timed travel



exact time parameters. Continue with STEP 5 if “DRIVE MOTORS” is selected or go to STEP 5A if “ENTER TIMES” is selected.

Step 5. Adjusting Gate Leaf Synchronising Delays. (Dual gate installations only)

For dual gate installations, the controller will prompt for you to edit the gate leaf synchronising delays. The settings are used to introduce a delay between when the motors start so that overlapping gates are opened and closed in the correct order. Press EXIT to continue with STEP 6 or press SET to access the gate leaf synchronising delay parameters **Fig. 24**. See PARAMETER VIEW AND EDIT for adjustment procedure.

Step 6. Confirming Gate Is Open

The controller will now prompt for you to confirm that the gate is open. If the gate is open press SET and continue with STEP 7 **Fig. 25**. Press EXIT if the gate is not open and the controller will now prompt for the gate to be opened by holding the UP key **Fig. 26**. When the UP key is released the motor(s) will stop and STEP 6 restarted.

Note: If the motor drives in the wrong direction the motor wiring needs to be swapped.

Step 7. Setting Close Cycle Drive Time

The controller is now ready for the close cycle drive time to be set **Fig. 27**. To do this simply press and hold the DOWN key until the gate is driven fully closed.

Note: If the motor drives in the wrong direction the motor wiring needs to be swapped.

Step 8. Setting Open Cycle Drive Time

The controller is now ready for the open cycle drive time to be set **Fig. 28**. To do this simply press and hold the UP key until the gate is driven fully open.

Step 9. Confirming Settings

The controller will now prompt you to save the settings. Press EXIT to restart from STEP 6 or, if you are happy with the settings press SET **Fig. 29** and the main screen will be displayed and the gate is ready to be used.



Setting timed travel - enter time

Entering Timed travel Parameters

When the ENTER TIMES method is selected a list of parameters is provided to configure the gates travel. The parameters provided are listed below with a brief description.

M1 Normal Open Time	-Sets Open drive time for M1
M1 Normal Close Time	-Sets Close drive time for M1
M2 Normal Open Time	-Sets Open drive time for M2*
M2 Normal Close Time	-Sets Close drive time for M2*
Close Sync Delay	-Sets Delay before M1 is started on close cycles*
Open Sync Delay	-Sets Delay before M2 is started on open cycles*

*Only used for dual gate installations. Once the parameter values have be set press EXIT and the main screen is displayed and the gate is ready for use.

Description of Standard Operation

This section describes the standard operation of the Dual Gate Controller with the factory set default values.

Motor Control.

The controller drives the motor in the appropriate direction as instructed by the control inputs. Once a cycle is started the motor will continue to travel until:

- 1.The controller is instructed to stop by a control input.
- 2.The motor's travel limit is reached.
- 3.The motor is obstructed, overloaded or stalls

When the control inputs instruct the Dual Gate Controller to change the motor direction, the controller brakes the motor, waits for the motor to stop and then starts the motor in the other direction.

Motor Obstruction Detection (only supported with limit switch type drive units)

If a motor is obstructed while opening, the motor is stopped. If the motor is obstructed while closing, the motor is stopped and then reversed to the open position. Obstruction detection is achieved by monitoring the motor's current and comparing it to the "normal" current profile for the motor. If the current of the motor rises above the "normal" by the MARGIN AMP setting, then the motor is said to be obstructed. In addition to the normal motor obstruction detection, motor overload and stall detection is provided to protect the gate opener and controller.

Motor Speed Control

The motor's speed is controlled by varying the voltage applied to the motor. When the motor is started the voltage is increased to the OPEN or CLOSE Speed Voltage parameter. When the limit switch of a drive unit is activated the motor is slowed so as to come to a gentle stop.

Lock Release Output

The lock release output is configured to pulse for 0.5 seconds at the start of each cycle. The output is turned on at the same time the motors are started. The output is provided on OUTPUT1.

Courtesy Light

The courtesy light is normally used to illuminate the driveway. The light will be turned on each time the gate is activated (day or night) and automatically turned off 1 minute after the drive cycle has finished. The light can also be activated and deactivated by pressing a transmitter button assigned the LGT function. The light output is provided on OUTPUT2 (requires additional light relay module RO-1).

Open / Stop / Close (Osc) Input

(Activated by OSC terminal with N/O switch or by transmitter button with OSC function assigned)

If the gate is stopped, the OSC input will cause the gate to move in the opposite direction to that last travelled. If the gate is moving the OSC input will cause the gate to stop.





Description of Standard Operation (cont.)

Pedestrian Access (Ped) Function

(Activated by PED terminal with N/O switch or by transmitter button with PED Function assigned)

The pedestrian access operation partly opens the gate to allow pedestrian access but prevent vehicle access. The position the gate leaf is driven to is automatically set to halfway during setting of the travel limits, but can be manually selected. Pedestrian access mode is entered when the input is activated and the gate is in the closed position. If the gate is not in the pedestrian access mode, the PED input will stop the gates if moving, or close the gates, if stopped. While in pedestrian access mode, the pedestrian access position temporarily becomes the open limit for the gate leaf. The PED input then acts with an OSC type function. The pedestrian access mode is exited when the gate is closed or when another input is activated.

Close (Cls) Input

(Activated by CLS terminal with N/O switch, by transmitter button with CLS function assigned or by the DOWN button on the console.)

Activating the CLS input will cause the gate to close. Holding the input active will prevent opening.

Swipe (Swp) Input

(Activated by SWP terminal with N/O switch or by transmitter button with SWP function assigned)

Activating the the SWP input will cause the gate to be opened. If the terminal input is held it will prevent the gate being closed. The swipe input also effects P.E TRIGGERED AUTO CLOSE.

Open (Opn) Input

(Activated by OPN terminal with N/O switch, by transmitter button with OPN function assigned or by console's UP button)

Activating the OPN input will cause the gate to open. Holding the input will prevent closing.

Stop (Stp) Input

(Activated by STP terminal with N/O switch, by transmitter button with STP function assigned or by console's EXIT button)

Activating the STP input while the gate is moving will cause the gate to be stopped. If the STP terminal is held it will prevent the gate from being moved.

Photoelectric Safety Beam (PE) Input

(Activated by PE terminal with N/C switch)

When the PE input is active, the gate is prevented from being closed. If the PE input is triggered while the gate is closing, the controller will stop the motors and then open the gate. The PE input has no effect while the gate is opening.

Vacation Mode

The controller supports a Vacation mode where remote control access is disabled. The mode is activated by pressing a transmitter button with the VAC function assigned until the console displays that vacation mode is enabled (approx. 5 seconds). When activated any transmitter button which is assigned VAC will be ignored. To turn the Vacation mode off, simply press a transmitter button with the VAC function assigned (Only requires a brief activation). Vacation mode can also be turned on or off manually by editing the VACATION MODE parameter. The controller can be instructed, via the pedestrian control feature, to partly open and provide pedestrian access but prevent vehicle access. This is achieved by partly opening the motor 1 gate leaf. If dual motors are used, motor 2's gate leaf is held closed. The partly open position of motor 1's gate leaf is initially set to a position halfway between open and closed. This initial position can be adjusted by the installer to any position within the gates travel range by selecting a pedestrian access travel time (from closed). The setting is accessed from "MENU 10.4 Set Pedestrian". The time is adjustable in 1 second steps.





Dual Gate Controller adjustments

The Dual Gate Controller's standard operation can be altered by editing various parameters. This section describes the parameters and the effect they have. Use the VIEWING AND EDITING PARAMETER PROCEDURE on Page 24 to make changes.

Menu 2. Current Trips

The obstruction margins are used to alter the sensitivity of the allowable variation between the "normal" speed profile and the controller to obstructions. Increasing the value increases the force required to detect an obstruction.

Parameter (Limit Switch)	Min	Max	Default	Step	Unit	Menu No.
M1 MARGIN Sets obstruction detection margin for M1	0.0	2.0	0.5	0.1	AMPS	2
M2 MARGIN Sets obstruction detection margin for M2	0.0	2.0	0.5	0.1	AMPS	2

Parameter (AMP Limits)	Min	Max	Default	Step	Unit	Menu No.
Motor 1 Open Limit AMPS Sets Motor 1 open limit detection current	0.0	8.0	2.0	0.1	AMPS	2
Motor 1 Close Limit AMPS Sets Motor 1 close limit detection current	0.0	8.0	2.0	0.1	AMPS	2
Motor 2 Open Limit AMPS Sets Motor 2 open limit detection current	0.0	8.0	2.0	0.1	AMPS	2
Motor 2 Close Limit AMPS Sets Motor 2 close limit detection current	0.0	8.0	2.0	0.1	AMPS	2
Maximum startup amps sets maximum permitted starting current of motors	0.0	6.0	5.0	0.1	AMPS	2

Parameter (timed travel)	Min	Max	Default	Step	Unit	Menu No.
Cutout AMPS maximum motor current permitted after startup	0.0	10.0	10.0	0.1	AMPS	2





Dual Gate Controller adjustments (cont.)

Menu 3. Auto-Close times

The Auto-Close modes automatically closes the gate after it has been operated. To implement this, the controller starts a timer once the gate has reached its desired open position. The timer then counts down and when it expires the controller starts to close the gate. Details of the four Auto-Close modes are outlined below. Automatic Technology strongly recommend using a PE Beam for added safety.

Standard Auto-Close

This mode is selected by entering a non-zero time for the **STD Auto-Close** parameter. When selected the gate will Auto-Close after being fully opened (except when the gate has reversed to the open position after a motor obstruction or overload). Countdown is suspended by: PE, OPN or SWP input being active. The countdown is aborted if the STP input is activated. If the gate is already open and the OPN or the SWP input is activated then the countdown will start.

PE triggered Auto-Close

This mode is selected by entering a non-zero time for the **"PE Auto-Close"** parameter. This mode is used to auto-close the gate but only after a vehicle have passed through the gateway and triggered the PE input. The swipe input can be used to clear the PE triggered status so that the PE input must be activated again before the countdown will start. As with the other PE modes, the STP input will abort countdown and the OPN and SWP inputs will restart the countdown if the gate is OPEN.

Pedestrian access Auto-Close

This mode is selected by entering a non-zero time for the **"Ped'n A/C"** parameter. When selected, the gate will Auto Close after being opened for pedestrian access unless it was following a reverse from an obstruction.

PE triggered pedestrian Auto-Close

This mode is selected by entering a non-zero time for the **"PE Ped'n A/C"** parameter. This mode is the same as the PE triggered auto-close mode but it only operates during pedestrian access. As the SWP input is not available during pedestrian access, the PED input can be configured to act in a SWP mode by setting the **"PED I/P = PED SWIPE MODE"** parameter to **ON**.

Auto-Close after obstruction

Two parameters are provided to enable the auto-close feature to be activated after obstructions. Normally the auto-close feature is not enabled after obstructions for safety reasons. PE beams must be used for these features to be activated.

Parameter	Min	Max	Default	Step	Unit	Menu No.
STD AUTO-CLOSE TIME Sets and enables the standard Auto-Close time	0.0	300.0	0.0	1.0	Sec	3
PE AUTO-CLOSE TIME Sets and enables the PE triggered Auto-Close time	0.0	60.0	0.0	1.0	Sec	3
PEDESTRIAN AUTO-CLOSE TIME Sets and enables the Pedestrian Auto-Close time	0.0	60.0	0.0	1.0	Sec	3
PE PEDESTRIAN AUTO-CLOSE TIME Sets and enables the PE Pedestrian Auto-Close time	0.0	60.0	0.0	1.0	Sec	3
AUTO-CLOSE AFTER CLOSE OBSTRUCTION Enables Auto-Close feature after close obstructions	Off	On	Off			3
AUTO-CLOSE AFTER OPEN OBSTRUCTION Enables Auto-Close feature after open obstructions	Off	On	Off			3





Dual Gate Controller adjustments (cont.)

Menu 4. Lock times

The Dual Gate Controller's lock function can be programmed for both hold and pulse operation. The lock output can also be programmed to activate prior to the motor starting. The open cycle and close cycle actions can be programmed differently. The lock can be either OUTPUT1 or OUTPUT2 (see OPERATING MODES).

Parameter	Min	Max	Default	Step	Unit	Menu No.
OPEN LOCK TIME Set the time the lock is activated for on open cycles	0.0	Hold	0.5	0.1	Sec	4
CLOSE LOCK TIME Set the time the lock is activated for on close cycles	0.0	Hold	0.5	0.1	Sec	4
PRE-OPEN LOCK TIME Time the lock is activated for prior to opening	0.0	25.5	0.0	0.1	Sec	4
PRE-CLOSE LOCK TIME Time the lock is activated for prior to closing	0.0	25.5	0.0	0.1	Sec	4

Menu 5. Light times

The Dual Gate Controller's light function can be programmed to operate a courtesy light or a warning light. The time the light stays on for after a cycle is adjustable. The light can also be activated prior to the gate moving so that a warning can be given of the pending movement. Note the light output can be selected to be either OUTPUT1 or OUTPUT2. The parameters are shown below.

Parameter	Min	Max	Default	Step	Unit	Menu No.
ON AFTER CYCLE LIGHT TIME Time light remains on for after a cycle	0	255	60	1	Sec	5
ON BEFORE OPEN CYCLE LIGHT TIME Minimum time light is activated for prior to opening	0	255	0	1	Sec	5
ON BEFORE CLOSE CYCLE LIGHT TIME Minimum time light is activated for prior to closing	0	255	0	1	Sec	5

Menu 6. Motor settings

Motor speed

The motor settings adjust various aspects of the gate travel. When a single gate installation is used the SYNC DELAY TIMES and M2 settings are ignored. The default value for the CLOSE SYNC DELAY time is automatically calculated for LIMIT SWITCH/AMP TRAVEL installations. The value calculated is selected so that the delay between M2 and M1 reaching the close position is equal to the OPEN SYNC DELAY TIME. The MAX OVERRUN TIME is set to 0 for TIMED TRAVEL installations.





Dual Gate Controller adjustments (cont.)

Parameter	Min	Max	Default	Step	Unit	Menu No.
CLOSE SYNC DELAY TIME Time delay between M2 and M1 closing	0.0	25.5	2.0	0.1	SEC	6.1
OPEN SYNC DELAY TIME Time delay between M1 and M2 opening	0.0	25.5	2.0	0.1	SEC	6.2
OPEN SPEED VOLTS Voltage applied to motors when opening	12	24	22	1	VOLTS	6.3
CLOSE SPEED VOLTS Voltage applied to motors when closing	12	24	20	1	VOLTS	6.4
SLOW SPEED VOLTS Voltage applied to motors when slowing down	6	24	8	1	VOLTS	6.5
SLOW TIME The time between slow down and end of cycle	0.1	10.0	3.0	0.1	SEC	6.6
STOP PAUSE TIME Pause time used between motor direction changes	0.0	2.0	0.2	0.1	SEC	6.7
M1 NORMAL OPEN TIME Normal open time for motor 1	0.0	60.0	0.0	0.1	SEC	6.8
M1 NORMAL CLOSE TIME Normal close time for motor 1	0.0	60.0	0.0	0.1	SEC	6.9
M2 NORMAL OPEN TIME Normal open time for motor 2	0.0	60.0	0.0	0.1	SEC	6.10
M2 NORMAL CLOSE TIME Normal close time for motor 2	0.0	60.0	0.0	0.1	SEC	6.11
MAX OVERRUN TIME Extra time allowed for cycle to complete (beyond normal cycle time)	0	60	5	1		6.12

Menu 7. Operating modes

PE input response mode

The PE input can be configured to respond in one of three modes.

Open and close cycles stop

In this mode, all cycles are prevented from being completed or initiated when the PE input is active.

Close cycles stop

In this mode, the PE input has no effect when opening but will stop the gate when closing.

Reverses close cycles

In this mode, the PE input has no effect when opening but will cause the gate to reverse if activated when closing.

PED input function

The PED input can be configured to a SWIPE type input for pedestrian access. This provides full functionality with the PE Triggered Pedestrian Auto-Close function.

Remote code

The controller supports the Remote Code Set feature. This parameter can be used to disable the feature for security or transmitter management reasons.





Dual Gate Controller adjustments (cont.)

Vacation mode

Vacation mode can be turned on or off using this parameter.

Battery/solar mode

The Dual Gate Controller can be instructed to turn off the Battery Backup facilities so that the Dual Gate Controller can be shut down without having to disconnect the Battery Backup system.

Password protection

The password feature enables all parameters and configuration settings to be protected unless a password is entered. When this feature is turned on the user is requested to enter the desired password to be used. The password protection feature has a time-out that expires after 60 seconds of inactivity. Alternately the user may log out manually by pressing exit when the main screen is displayed.

Open input polarity

The OPN input is normally configured for N/C operation. This parameter allows its operation to be changed to N/O.

Parameter	Min	Max	Default	Menu No.
PE INPUT RESPONSE MODE Sets the PE response mode. Options are OPEN and CLOSE cycles stop, Close cycles stop or Close cycle reverse	NOT USED	OPN & CLS stop CLS to stop CLS to reverse	CLS to reverse	7.1
PED INPUT = SWIPE MODE Selects PED input functions as pedestrian access swipe input	Off	On	Off	7.2
REMOTE CODE ENABLED Selects remote transmitter coding function	Off	On	On	7.3
VACATION MODE Selects vacation mode - disables remote control	Off	On	Off	7.4
BATTERY/SOLAR MODE Selects Battery Backup/Solar operation	Off	On	On	7.5
PASSWORD Selects password protection for all changes	Off	On	Off	7.6
TX # GROUPING Selects transmitter number group display format.	Off		Off	7.7
OPN INPUT N/C OPERATION Selects operating polarity of OPN input	Off	On	Off	7.8
STP INPUT N/C OPERATION Selects operating polarity of STP input	Off		Off	7.9
OUTPUTS 1&2 Selects function of OUTPUT1 and OUTPUT2	OUTPUT1= LOCK OUTPUT2= LIGHT	OUTPUT1= LIGHT OUTPUT2= LOCK	OUTPUT1= LOCK OUTPUT2= LIGHT	7.10
OPN INPUT = 2ND PE Open input acts as 2nd PE input				7.11
FAULT AUTO RESET				7.12





Viewing and editing parameters

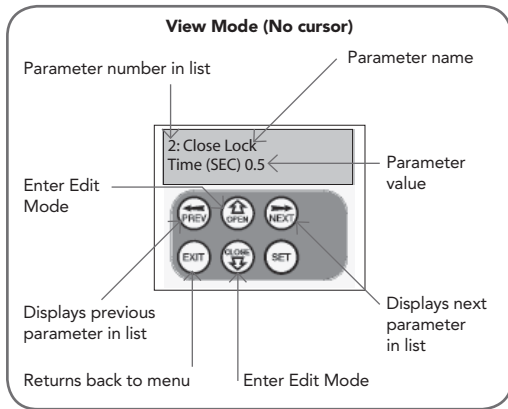

This section illustrates how to locate, view and adjust parameters.

Locating parameters

Refer to MENU STRUCTURE on Page 10 or the preceding section for CONTROL BOARD ADJUSTMENTS. Locate the required parameter and note the MENU number. The example used in (Fig. 30) displays "CLOSE LOCK TIME"

Changing setting

1. Press NEXT/PREV to navigate to the required menu.
2. Press SET to show sub-menu.
3. Press NEXT/PREV to go to required sub-menu.
4. Press SET to enter edit mode.
5. Press UP/DOWN to change parameter setting.
Holding the button down causes the parameter's values to change rapidly. The longer the button is held, the faster the value changes.
6. Press SET to SAVE setting.

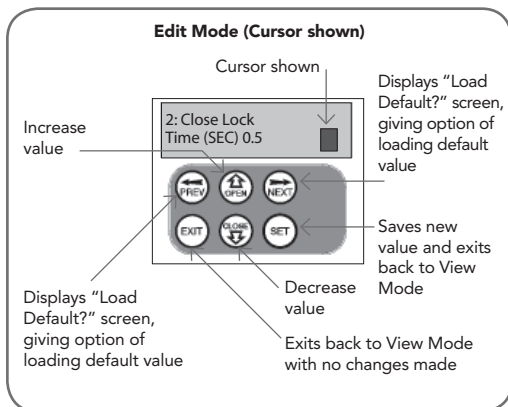

Reload default setting

1. Press NEXT/PREV buttons to display LOAD DEFAULT screen.
2. Press SET to load the default value.

Return to menu

If the parameter values are not to be changed, press EXIT to return to sub menu. Press EXIT again to return to the MAIN SCREEN.





Coding transmitters

The Dual Gate Controller can store up to thirty (30) transmitters in its memory. Each transmitter can be allocated an alpha-numeric ID label up to eleven (11) characters in length and each button can be assigned to one of several control functions. The settings for a transmitter are represented in (Fig. 32). It shows the transmitter's store number, ID label or serial number and the functions assigned to each of its four buttons. To toggle between ID/SN display, press UP/DOWN with the cursor on the ID/SN indicator. The procedures below code, delete, replace, edit and copy transmitter records.

BRAND OF TRANSMITTERS

First memory location sets the type of transmitters which can be stored into the memory of the receiver. It either can be ATA TrioCode™ or B&D Tri-Tran™ transmitters. For example, if first transmitter stored is TrioCode™ then rest of transmitters can only be the TrioCode™ type and mixing of TrioCode™, Tri-Tran™ is not possible. By deleting all stored transmitter codes from the receivers memory will allow you to choose either TrioCode™ or Tri-Tran™ transmitters again.

Coding transmitter button

Step 1. Navigating to "code transmitter" menu

1. Press NEXT to navigate to the Menu 1 (Fig. 33).
2. Press SET to enter code set procedure.

Step 2. Storing transmitter code

1. Controller will prompt to press one of the transmitter's buttons.
2. Press the transmitter button you wish to use to operate the Gate Opener (e.g. button 1) (Fig. 34).
3. Press same transmitter button again as prompted by display (Fig. 35).

Step 3. Selecting function of the button

The controller will now show the transmitter's record, with a cursor on the field for the button being coded (Fig. 36). Use UP/DOWN to select the function for the button.

Available functions:

VAC (Vacation Mode)	LGT (Courtesy Light)
STP (Stop)	OPN (Open)
CLS (Close)	SWP (Swipe)
PED (Pedestrian access)	OSC (Open/Stop/Close)
OFF (No action)	

Press SET to save the settings (Fig. 37) or EXIT to abort without saving.

Returning to main screen

The "Code Transmitter" menu will now be shown. Press EXIT to return to the MAIN SCREEN and test the transmitter.

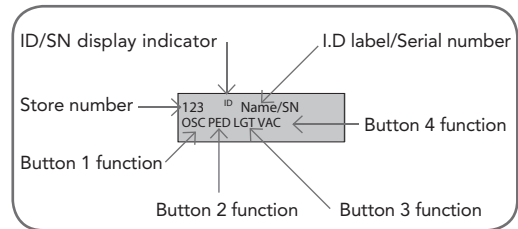

fig 32

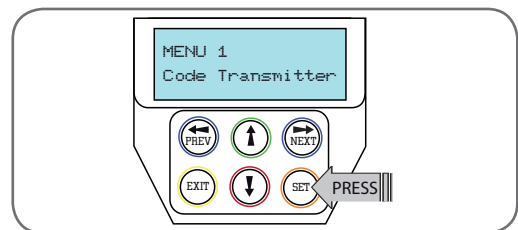

fig 33

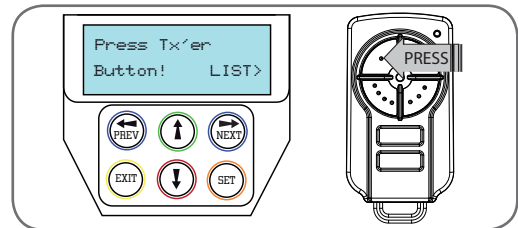

fig 34

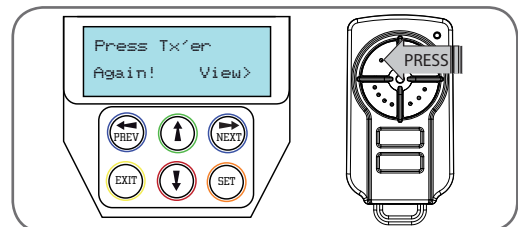

fig 35

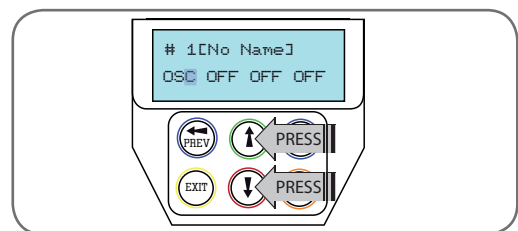

fig 36

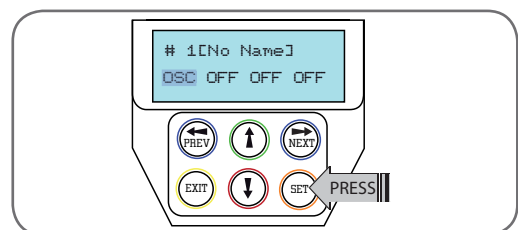

fig 37





Transmitter editing

fig 38

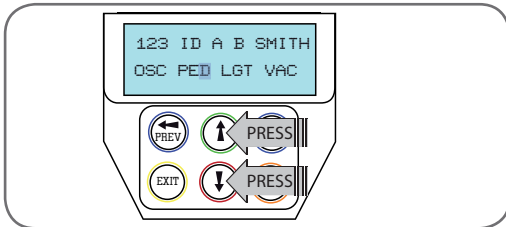

fig 39

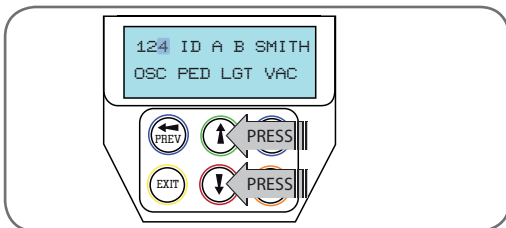

fig 40

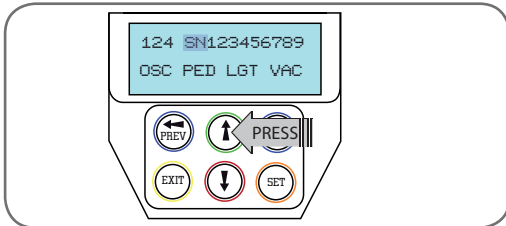
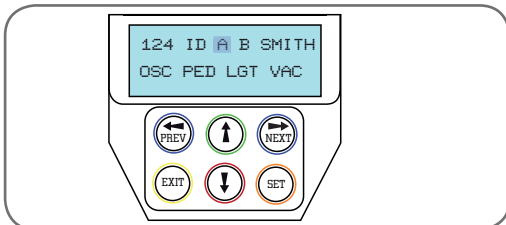

fig 41



Editing transmitter settings

Step 1. Display transmitter record

Using one of the methods below, display the required transmitters details.

Step 2. Navigating to "edit transmitter" menu

1. Press NEXT to navigate to the Menu 1.
2. Press SET to enter the transmitter edit procedure.
3. Press NEXT to enter transmitter list and edit mode.

Step 3. Editing button function field

1. Press NEXT or PREV to move the cursor to the left or right and between the top and bottom lines to select the desired field.
2. Press UP or DOWN to change the displayed value (**Fig. 38**). The available functions are shown below. Selecting OFF will prevent the opener responding to that button.

Available functions

VAC (Vacation Mode)	LGT (Courtesy Light)
STP (Stop)	OPN (Open)
CLS (Close)	SWP (Swipe)
PED (Pedestrian access)	OSC (Open/Stop/Close)
OFF (No action)	

3. Press SET to save changes or press NEXT or PREV to move to next field. The example in (**Fig. 38**) shows that PED is assigned to the transmitter button 2. The transmitter in the example is transmitter number 123 which has the ID label AB Smith.

NOTE: If all button functions are set to OFF, when SET is pressed, the opener will prompt to confirm if the transmitter is to be deleted. Press SET to delete or EXIT to continue editing.



Transmitter editing (cont.)

Step 4. Editing the store location

This feature is only available when coding the first button of a new transmitter.

1. Press NEXT or PREV to move cursor over Store No.
2. Press UP or DOWN to select new Store No (**Fig. 39**).
3. Press SET to Confirm or NEXT/PREV to move to next field.

This is useful when managing transmitters using a scheme which ties the store location to the owner of the transmitter.

Step 5. Selection of ID or Serial Number display

1. Press NEXT/PREV to move cursor over ID field.
2. Press NEXT to reveal Serial Number (**Fig. 40**).

The serial number display is provided for additional means of identification. The transmitter in this example has serial number 123456789.

Step 6. Editing a character field

1. Press NEXT or PREV to move select character to change.
2. Press UP or DOWN to scroll through and select new character (**Fig. 42**).
3. Press NEXT or PREV to move to next character.
4. Repeat step 2.
5. Press SET to record changes (**Fig. 43**).

The second line of the display shows a list of available characters with the current value indicated at the cursor position.

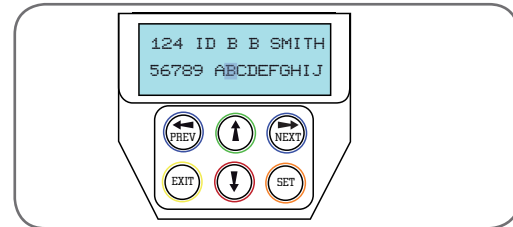

fig 42

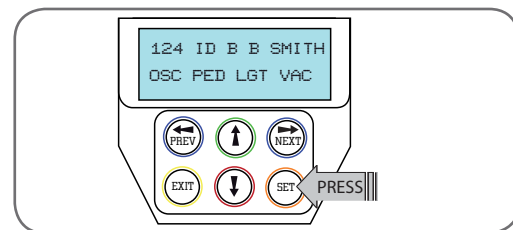

fig 43





Transmitter management

fig 44

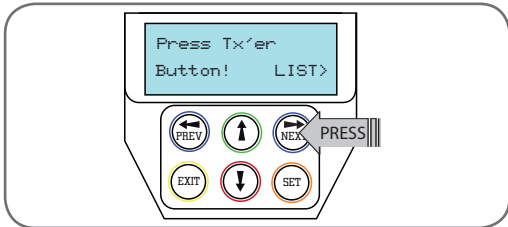

fig 45

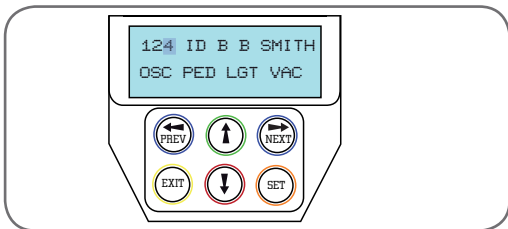

fig 46

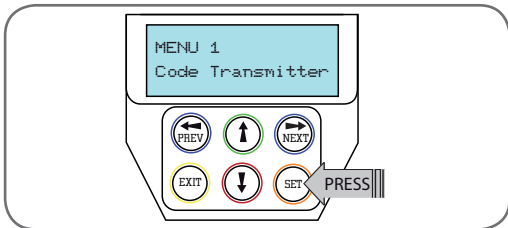

fig 47

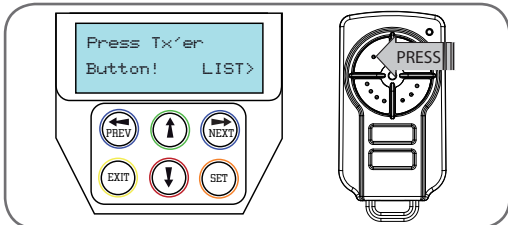
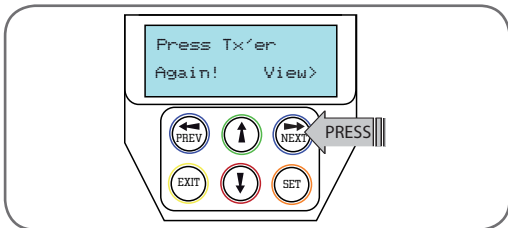

fig 48



The Dual Gate Controller provides a transmitter listing facility which enables the user to find a transmitter location within memory. Once located a stored transmitter can be replaced, deleted, edited, copied or, if the location is empty, a new transmitter can be coded.

Method 1 - Go to the start of the list

Step 1. Accessing the list menu

1. Press NEXT to navigate to the Menu 1 (Fig. 44).
2. Press SET to enter the transmitter edit procedure.
3. Press NEXT to enter transmitter list and edit mode

Method 2 - Use transmitter to go direct to list

Step 1. Accessing the list menu

1. Press NEXT to navigate to the Menu 1.
2. Press SET to enter the transmitter edit procedure.
3. Press transmitter once (Fig. 47).
4. Press NEXT to view transmitter parameters (Fig. 48).
Used for quick navigation if the transmitter is available.

NOTE: "VIEW>" will not be shown if the transmitter is not stored.



Transmitter management (cont.)

Once the list is displayed it can be sorted by stored number, ID Label or Serial Number. Use NEXT or PREV button to select sorting method.

NOTE: When sorting by ID label or S/N, only stored transmitters locations are displayed.

Step 2. Navigating the list

1. Press UP or DOWN buttons to navigate through list (**Fig. 49**).
2. Press SET to display menu of available functions.

NOTE: Holding a button down will step through the list faster.

Selecting an operation

Press NEXT or PREV to cycle through four menu options (**Fig. 51-54**). Press EXIT to return to the list. Press SET to execute the menu's operation.

Code operation (location empty)

If the code operation is selected on an empty transmitter location, the BASIC CODE TRANSMITTER PROCEDURE will be initiated with the transmitter being saved in the selected location. This is useful when managing transmitters using a scheme which ties the store location to the transmitter's owner.

Code operation (location used)

If the code operation is selected for a location that already contains a transmitter, then the BASIC CODE TRANSMITTER PROCEDURE will be initiated and the new transmitter will replace the existing one. Note that the button functions and name of the existing transmitter will be transferred to the new transmitter. This procedure is of great convenience when replacing a lost transmitter.

Delete operation

The delete operation is used to remove a transmitter from memory along with the name and button function settings.

Edit operation

The edit operation displays the transmitter record for editing purposes. See TRANSMITTER EDIT PROCEDURE for details.

Copy operation

The copy operation is used to code multiple transmitters with the same button function as that of the selected transmitter. Once selected an abbreviated code set routine is initiated which repeats steps 2 & 3 of the BASIC CODE TRANSMITTER PROCEDURE for each transmitter to be coded. Coding is terminated by pressing the EXIT button.

Exiting the list

To exit the transmitter list simply press EXIT to return to the Code.

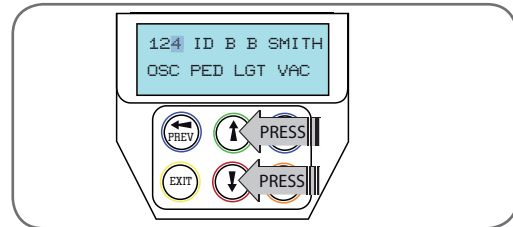

fig 49

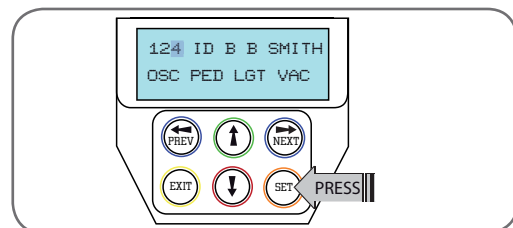

fig 50

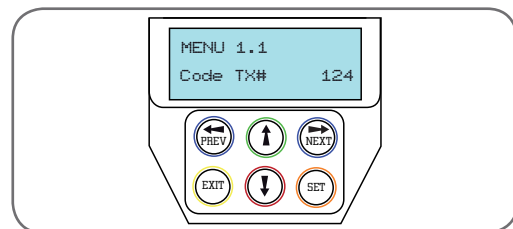

fig 51

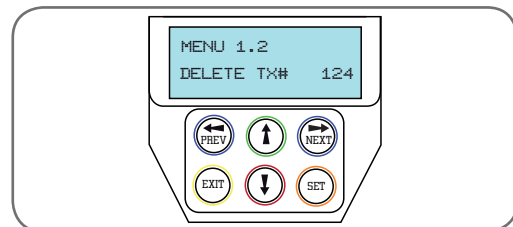

fig 52

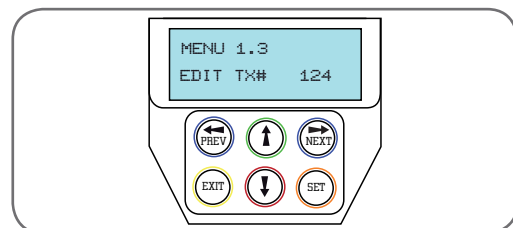

fig 53

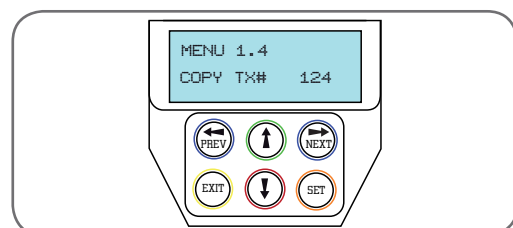

fig 54





Remote code set procedure

fig 55

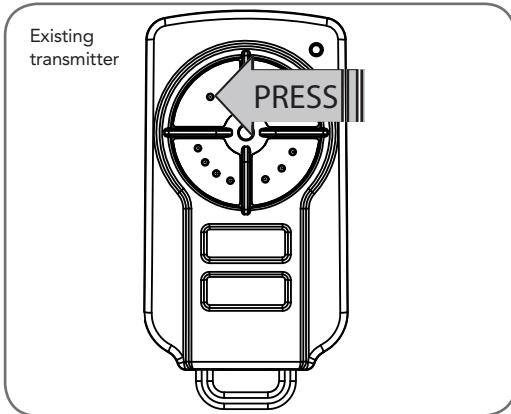

If a transmitter is already coded into the opener, additional transmitters can be coded without being in direct contact with the Dual Gate Controller.

NOTE: Only the function of the existing transmitter button can be assigned to new transmitter. Please read instructions prior to proceeding - there is a time-out facility for security reasons.

1. Selecting the function to be coded

Using the existing transmitter, operate the gate with the transmitter button which has the function to be coded (**Fig. 55**) (e.g. Button 1 has been coded with the OSC function assigned).

2. Wait for gate to complete cycle

If the button's function activates the gate (PED, SWP, OSC, CLS, STP or OPN) wait for the gate to complete its cycle.

3. Activate remote code set mode

Using a small pin press and hold through the Coding Hole of the existing transmitter for two seconds (**Fig. 56**).

4. Code new transmitter button

Within 10 seconds, press the button on the new transmitter you wish to code for 2 seconds (**Fig. 57**).

5. Confirm transmitter button to be coded

Press the same button again (within 10 seconds) for confirmation.

6. Test operation

The new transmitter button should now function as the existing transmitter.

NOTE: When a transmitter is remote coded, its ID label is set to that of the existing transmitter. If the existing transmitter does not have an ID label assigned, then the ID label of the new transmitter is set to: R/C Tx ###, where ### is the existing transmitters store number. This ensures that the originator of any remote coded transmitter can be identified.

fig 56

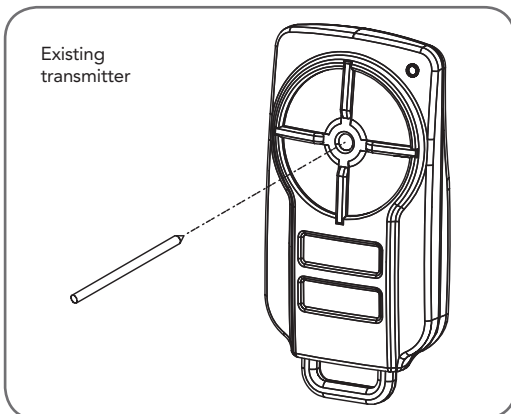
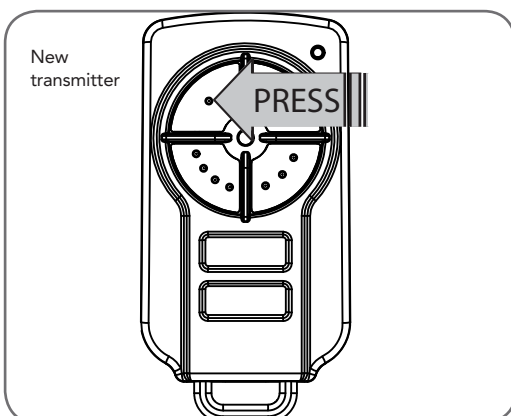

fig 57





Diagnostic tools

The controller provides several diagnostic tools from within the diagnostics menu (Menu 8) this section details the function of each tool and its use.

Navigating to diagnostics menu

1. Press PREV to navigate to Menu 8 (Fig. 58).
2. Press SET to display menu of available functions.
3. Press PREV or NEXT to cycle through diagnostic tool.
4. Press SET to select.

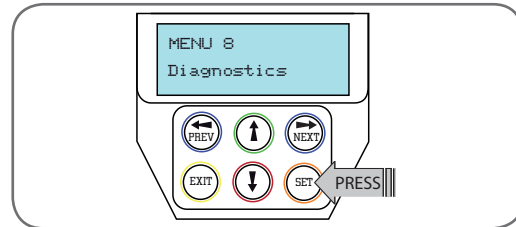

fig 58

Menu 8.1 Test inputs

This tool is used to view the state of the control inputs. When selected, a screen is displayed (Fig. 59) which indicates the state of each input. If the name of the input is in uppercase then the input is active, conversely if the input is in lower case then the input is inactive. For normal operation all inputs should be inactive. When finished press EXIT. The example shows the status as OSC input is active.

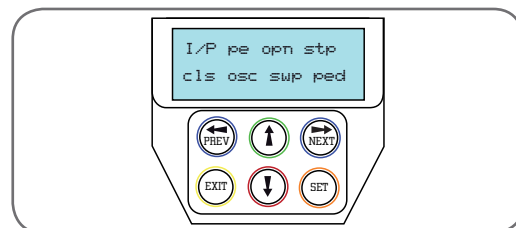

fig 59

Menu 8.2 Test tx'ers

This tool is used to test receiver/transmitter functionality. When selected, a screen is displayed which prompts for a transmitter button to be pressed (Fig. 60) and whether ID or serial numbers are to be displayed.

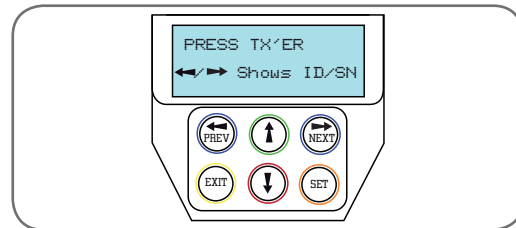

fig 60

The Dual Gate Controller will then beep each time a transmission is received. If the transmitter button is stored in the controller memory and has a function assigned to it, a second screen will be displayed that shows the transmitter details along with the button pressed (Fig. 61). The example shows the case when transmitter number 12 is activated by button 4. Note ID is selected for display.

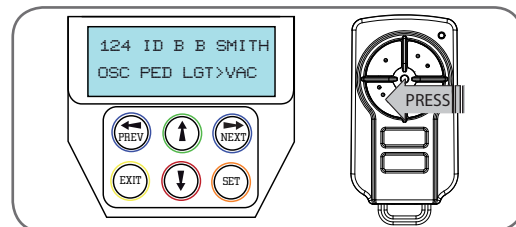

fig 61

Menu 8.3 Display history

Dual Gate Controller keeps a record of the last 64 events that have taken place. The events include the type of drive cycles executed, obstruction detection, various faults, power failures etc. When this tool is selected, the screen displays the last event that occurred (Fig. 62). Press NEXT or PREV to view each event. The "EVENT#" field shows the sequence of the events, with (1) being the first and (64) being the last. The example shows that the last event was a close cycle which succeeded in closing the gate. When finished viewing the events, press EXIT.



fig 62

Menu 8.4 Memory usage

This tool displays the number of transmitter store location used and the number free (Fig. 63).

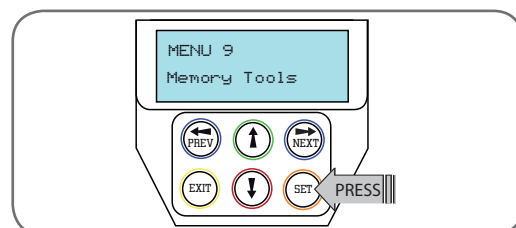

fig 63





Diagnostic tools

fig 64

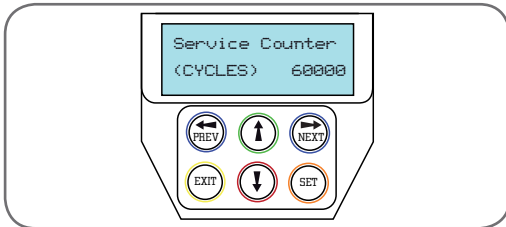
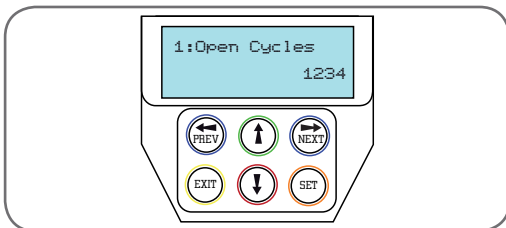

fig 65



Menu 8.5 Service counter

The Dual Gate Controller provides a periodic service counter which can be set to expire after a number of drive cycles. When expired, the Dual Gate Controller will beep at the beginning of each drive cycle and a message will be displayed on the MAIN SCREEN (**Fig. 64**). This tool displays the current value of the service counter and allows the user to set its value using the normal parameter editing techniques (See PARAMETER VIEWING AND EDITING). If the service counter is not to be used it can be set to the maximum number (60,000).

Menu 8.6 Counters

The opener keeps a count of number of times a particular event occurs. The list of event counters kept is shown below. When this tool is selected the first event counter is shown (**Fig. 65**). Press NEXT or PREV to step through the list. The example below shows the OPEN CYCLE event counter with a value of 1234. When finished viewing press EXIT.

- 1: Open Cycles
- 2: Close Cycles
- 3: Ped Cycles
- 4: Setup Limits
- 5: Comm's Loss
- 6: Sync Faults
- 7: Overlaps
- 8: M1 Open Stall
- 9: M1 Close Stall
- 10: M1 Open Obstructions
- 11: M1 Close Obstructions
- 12: M1 Open Overloads
- 13: M1 Close Overloads
- 14: M1 PWM Sync Faults
- 15: M1 PWM Drive Faults
- 16: M1 Direction Faults
- 17: M1 Sensor Faults



Memory tools

The Memory Tools accessed from within Menu 9 are used to backup, restore or clear the controller. Once selected, the PREV or NEXT buttons can be used to view the Memory Tool options. To Execute the displayed option simply press SET (**Fig. 66**).

Menu 9.1 Clr control

This option will clear the gate control memory and reload the factory set defaults for parameters such as the lock time, light time, auto-close times etc. It will also clear the travel limits.

Menu 9.2 Clr tx'ers

This option will clear the transmitter storage memory.

Menu 9.3 Backup tx'ers

This option saves a copy of the transmitter memory into a memory module connected to the controllers programmer connector.

Menu 9.4 Restore tx'ers

This option will restore the transmitter memory from the inserted memory module.

Menu 9.5 Import labels

This option will overwrite the current transmitter labels with those stored in the inserted memory module. This option is provided so that transmitter labels entered using Transmitter Management software on a P.C can be loaded into memory without altering the transmitters themselves.

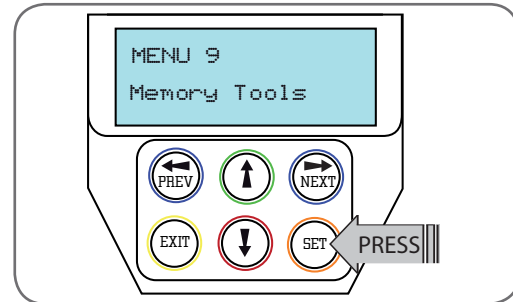

fig 66





Setting pedestrian position

The Dual Gate Controller can be instructed, via its pedestrian control feature, to partly open and provide pedestrian access but prevent vehicle access. This is achieved by partly opening the motor 1 gate leaf. If dual motors are used, motor 2's gate leaf is held closed. The partly open position of motor 1's gate leaf is initially set to a position halfway between open and closed. This initial position can be adjusted by the installer to any position within the gates travel range by selecting a pedestrian access travel time (from closed). The setting is accessed from "MENU 10.4 Set Pedestrian". The time is adjustable in 1 second steps.

NOTE: Before setting the pedestrian access position the gate must be in the fully closed position. As with the Setting Travel Limit procedure, a transmitter can be used to complete the pedestrian position setting procedure.

Step 1. Navigating to "set pedestrian menu"

1. Press PREV to navigate to Menu 10 (**Fig. 16**).
2. Press SET - MENU 10.1 is displayed.
3. Press NEXT to go to MENU 10.4.
4. Press SET to enter Set Pedestrian procedure.

Step 2. Setting pedestrian position

1. Press OPEN or CLOSE to adjust pedestrian drive time.
2. Press SET to record position
3. Press transmitter coded for pedestrian function or push button wired into pedestrian input to test.



Accessories installation

Fitting the PE Beams (optional)

- Affix the PE Beams in a strategic location within the gateway. We recommend 150mm above the floor level and as close as possible to the gate opening.
- Connect the wires from the PE Beams wiring harness to terminal block (Fig. 67). The wiring diagram is for Model PE-2 (Order Code 90214).
- Make sure that you are using the correct resistor i.e. 2k2 ohms (Red Red Red Gold) and connecting to number 2 (two) and 4 (four) terminal on the PE-2 receiver. Make sure to align the beams correctly. Follow the manual supplied with the PE Beams.



WARNING: When using PE Beams, the gateway must be clear of all obstructions and persons at all times. The location of the beams and manner in which it is installed might not give safety protection at all times. Check to make sure that the height of the beam and type used give maximum protection possible.



WARNING: Install the PE Beams as per diagram in (Fig. 46). **Tampering with PE Beams** could result in serious personal injury and/or property damage and will void the warranty.

Wiring Output1 And Output2

Outputs 1 and 2 are used to control a lock and a light. Which output is to control which function and the way it is controlled is programmable. If using these outputs make sure that the functions are configured for correct operation prior to setting the travel limits. OUTPUT1 is a relay output with high current capability. OUTPUT2 is used to activate an optional external relay module (RO-1) which in turn is used to switch the load.

Fitting solenoid or magnetic locks

Install the lock mechanism on the gate as per the manufacturers instructions. The wiring diagram at right is a representation of a typical lock with a bias for normally closed contact (Fig. 68).

Fitting courtesy lights

An AC or DC courtesy light can be activated via an output on the gate opener control board. Connect the light as per the diagram at right (Fig. 69).



WARNING: A qualified electrician must perform the installation where 240V AC power is used.

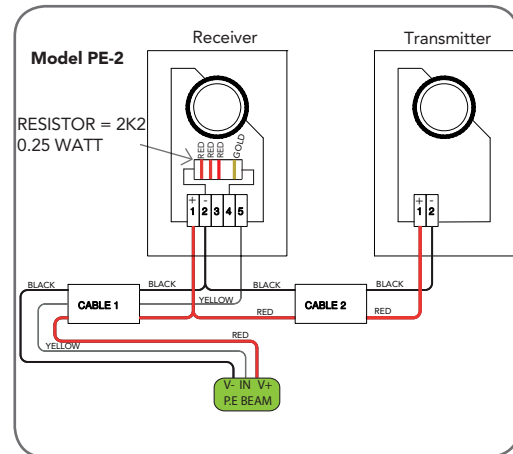

fig 67

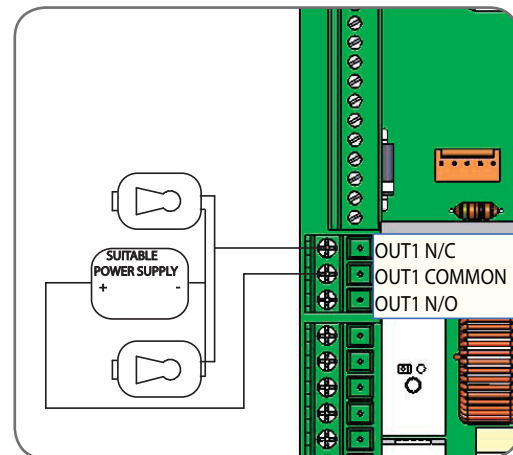

fig 68

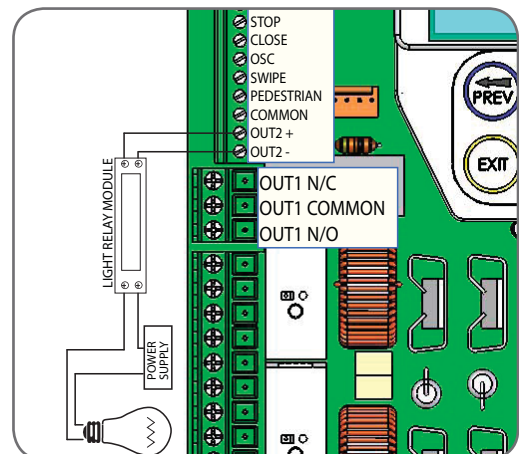
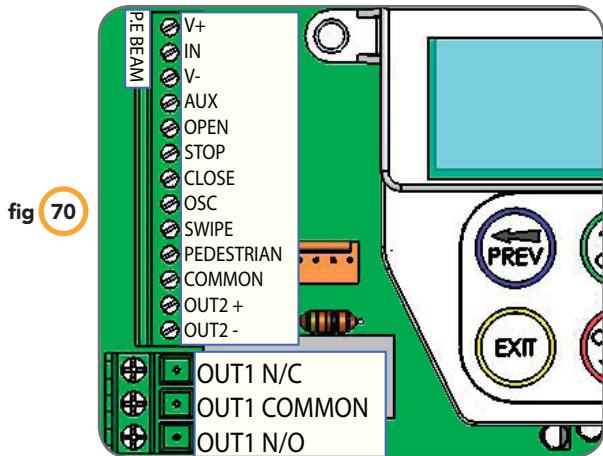

fig 69





Wiring Control Inputs

The console switch inputs may be used for operating the gate via any device that provides a switch contact output.

AUX, OPN, STP, CLS, SWP, PED requires normally open contact switches. OPN and STP inputs can be configured to take normally close contact switches.

Battery Backup installation

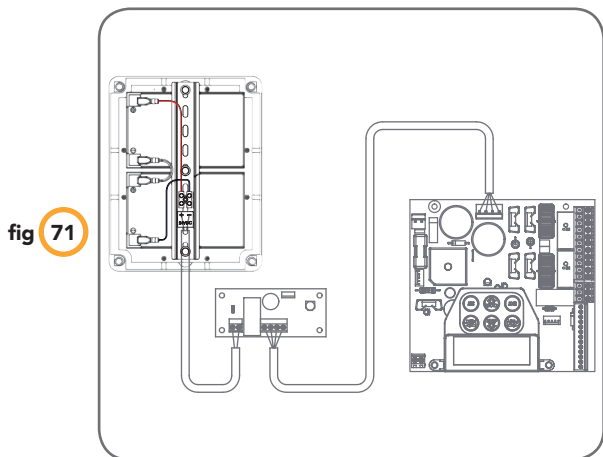

Connect the Battery Backup Kit

1. Disconnect power to the gate controller.
2. Secure the SBY-3 Charger Board in the controller box with sticky pads (supplied with the battery charger kit part number # 90188).
3. Connect the SBY-3 charger board to battery box and to Dual Gate Controller as shown (Fig 51).
4. Reconnect power.
5. From menu 7.7 select the "battery enabled option"

Testing Battery Backup

1. Press transmitter to test the gate opener.
2. Whilst gate is in motion, disconnect mains power. The gate should continue to operate as normal.

NOTE: Wait for the gate to complete its travel.

3. Press the transmitter to activate the gate.
4. Whilst gate is in motion re-connect power. The gate should complete the cycle as normal.

Troubleshooting

If gate stops or moves very slowly under battery power, the batteries may be weak or have no charge. Connect mains power and allow the batteries to charge. This may take 24 - 48 hours to reach maximum charge capacity.





Specifications

Technical Specifications

Protection rating:	IP33
24VDC accessory output	24VDC (unfiltered) 3Amp maximum
Secondary voltage:	24V AC 150 VA
Motor voltage:	12 to 24V DC @ 10AMPS max combined
Receiver type:	433.92 MHz TrioCode™ or Tri-Tran™ ¹
Receiver code storage capacity:	30 x 4 Button Transmitter Codes ²
Transmitter frequency:	433.92 MHz
Coding type:	Hopping Code
No. of code combinations:	Over 4.29 billion random codes
Code generation:	Non-linear encryption algorithm
Transmitter battery:	CR2032

NOTE:

1. The first memory location sets the type of transmitters which can be stored into the receivers memory. It either can be ATA TrioCode™ or B&D Tri-Tran™ transmitters.
2. The storage memory can be increased from 30 transmitters to 511. Contact ATA for details.

NOTE: Specifications are subject to change without notice.





Notes and record

Purchased from: _____ Phone: _____

Installed by: _____ Date: _____

Serial No: _____





Warranty and exclusion of liability

1. This warranty is an addition to any non-excludable conditions or warranties that are implied into this contract by relevant statute, including the Trade Practices Act 1974 (Cth).
2. Subject to all of the matters set out below, Automatic Technology Australia Pty Ltd ("ATA") warrants:
 - (a) swing and sliding gate opener drive units for twelve (12) months or 2500 cycles, whichever occurs first;
 - (b) roll-up and overhead door opener drive units for twenty four (24) months or 5000 cycles, whichever occurs first; and
 - (c) all components and accessories for twelve (12) months, from the date of purchase (specified in the sales docket receipt) as free of any defects in material and workmanship.
3. This warranty applies only where the purchaser:
 - (a) immediately notifies ATA or the retailer of the alleged defect;
 - (b) returns the product to the retailer; and
 - (c) presents the relevant sales docket and this warranty document to the retailer to confirm the date of purchase.
4. Except for this warranty, ATA gives no warranties of any kind whatsoever (whether express or implied), in relation to the product, and all warranties of whatsoever kind relating to the product are, to the extent permissible by statute, hereby excluded.
5. To the extent permissible by statute, ATA disclaims any liability of whatsoever nature in respect of any claim or demand for loss or damage which arises out of:
 - a) accidental damage to or normal wear and tear to the product or to the product's components;
 - b) any cost relating to damage resulting from wear and tear;
 - c) blown fuses, loss or damage caused by electrical surges, power surges or power spikes;
 - d) loss or damage due to theft, fire, flood, rain, water, lightning, storms or any other acts of God;
 - e) maximum continuous operating time exceeding one (1) minute in ten (10);
 - f) maximum operating force exceeding 15kg (150N) when moving the door or gate manually to the open or closed position;
 - g) door surface area and/or weight exceeding 15m² and 100kg respectively;
 - h) residential gate weight exceeding 400kg;
 - i) door or gate not in safe and correct working order and condition;
 - j) evidence of unauthorised repairs;
 - k) any cost relating to damage caused by misuse, negligence or failure to maintain the equipment in a proper working order as per clauses (d) through (i);
 - l) installation, adjustment or use which is not in accordance with the instructions set out in installation instruction manual;
 - m) attempted or complete modification or repairs to the product carried out by a person who is not authorised or has not been trained by ATA to carry out such modification or repairs;
 - n) faulty or unsuitable wiring of structure to which the product is fixed or connected;
 - o) radio (including citizen band transmission) or any electrical interference;
 - p) damage caused by insects;
 - q) loss or damage to any property whatsoever or any loss or expense whatsoever resulting or arising there from or any consequential loss;
 - r) any cost or expense arising due to manufacturer recall of any product;
 - s) any cost or expense due to negligence of the approved service provider;
 - t) installation of a residential garage door or gate opener in a commercial or industrial situation or a non-single residential dwelling.
6. ATA's liability under this warranty is limited, at ATA's absolute option, to replacing or repairing the product which ATA, in its unfettered opinion, considers to be defective either in material and/or workmanship or to credit the dealer with the price at which the product was purchased by the dealer.
7. This warranty does not extend to cover labour for installation.
8. This warranty is limited to Return-to-Base (RTB) repair and does not cover labour for on-site attendance.
9. This warranty is void if the Product is not returned to the manufacturer in original or suitably secure packaging.
10. This warranty is only applicable for repairs to the product carried out within Australia.
11. This warranty does not cover consumable items including globes, batteries and fuses.
12. This warranty is not transferable.
13. Where the Product is retailed by any person other than ATA, except for the warranty set out above, such person has no authority from ATA to give any warranty or guarantee on ATA's behalf in addition to the warranty set out above.

NOTES:

1. One (1) cycle = one (1) open and one (1) close action of the door or gate.
2. This warranty is to be read in conjunction with the owner's copy of the installation instruction manual.





© October 2008 Automatic Technology (Australia) Pty Ltd. All rights reserved. TrioCode™ is a trademark of Automatic Technology (Australia) Pty Ltd. No part of this document may be reproduced without prior permission. In an ongoing commitment to product quality we reserve the right to change specification without notice. E&OE.

automatic
TECHNOLOGY

smart | simple | secure

an alesco company

Automatic Technology (Australia) Pty Ltd

ABN 11 007 125 368

6-8 Fiveways Boulevard
Keysborough, Victoria, 3173, Australia

P 1300 133 944

+61 2 9722 5666 (International Enquiries Only)

E sales@ata-aust.com.au

www.ata-aust.com.au