

4th Edition

# Motor Controller Single Gate with Eclipse® Operating System (EOS)

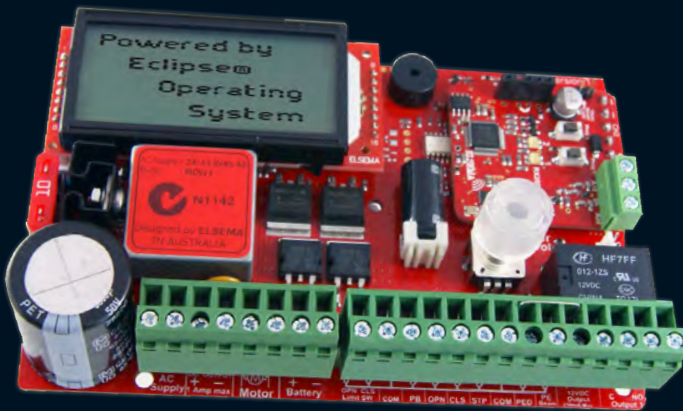

**ELSEMA**  
GATE & DOOR CONTROLS  
[www.elsema.com](http://www.elsema.com)

MCS : Motor Controller Single  
Setup and Technical Information  
Includes latest Intelligent Technology

## Important warning and safety instructions

All installations and testing must be done only after reading and understanding all instructions carefully. All wiring should be done only by trained technical personnel. Failing to follow instructions and the safety warnings may result in serious injury and/or damage to property.

Elsema Pty Ltd shall not be liable for any injury, damage, cost, expense or any claim whatsoever to any person or property which may result from improper use or installation of this product.

Risk in the goods purchased shall unless otherwise agreed in written pass to the buyer upon delivery of the goods.

Any figures or estimates given for performance of goods are based upon the company's experience and is what the company obtains on tests. The company will not accept liability for failure to comply with the figures or estimates due to the nature of variable conditions affecting for example Radio Remote Controls.

Please keep this setup instruction for future reference.



Installed by: \_\_\_\_\_

Service date: \_\_\_\_\_

# Contents

Features .....	4
Description.....	4
Part Number.....	5
Menu Structure .....	6
Connection Diagram .....	8
Supply and Motor Inputs .....	9
Limit Switches.....	10
Setup i-Learning Steps.....	11
Menu 1 – Auto Close.....	12
Menu 2 – Pedestrian Access Features .....	13
Menu 3 – Input Functions.....	14
Menu 4 – Photoelectric Beam.....	15
Menu 5 – Relay Output Functions.....	16
Menu 6 – <b>Relay Output Modes</b> .....	<b>19</b>
Menu 7 – Special Features.....	22
Menu 8 – Motor Obstruction.....	23
Menu 9 – Motor Speed and Slow Speed Area.....	24
Menu 10 – Anti-Jam and Braking .....	25
Menu 11 – i-Learning.....	26
Menu 12 – Password.....	26
Menu 13 – Operational Records.....	26
Menu 14 – Tools.....	27
Accessories.....	28
PentaFOB® Programming Instructions.....	30

## Features

- › Lithium-ion and lead acid battery charger
- › Suitable for single swing and sliding gates
- › Single motor operation
- › Eclipse Operating System (EOS)
- › Motor soft start and soft stop
- › Slow speed and force adjustment
- › Large 4-line LCD to indicate controllers status and setup instructions
- › 1-Touch control for easy setup
- › Various inputs, push button, open only, close only, stop, pedestrian and Photoelectric Beam
- › Supports limit switch inputs or mechanical stops
- › Adjustable Auto Close and Pedestrian Access
- › Adjustable lock and courtesy light outputs
- › Variable photoelectric safety beam functions
- › 12 Volt DC Output to power accessories
- › Service counters, password protection, holiday mode and many more features

## Description

The Motor Controller Single (MCS) is not just the next generation but the industry game changer. We wanted to create a controller that is simple to use and does just about any feature required in the gate and door industry. The MCS is not just the next generation but the “Next Transformation” in the gate and door industry creating an Eclipse over previously developed motor controllers.

This new intelligent motor controller is the best match for your automatic gate or door motors.

The MCS's Eclipse® Operating System (EOS) is a user friendly menu driven system that uses the 1-touch button to control, setup and run automatic gates, doors and barriers. It uses a large 4-line LCD screen showing live reading of the motor performance and status of all inputs and outputs.

The intelligent controller was built from the ground up, based on customer feedback and using today's technology. With its rich functions, consumer friendly price and with the focus during development being ease of use and setup makes this controller the ultimate board to control your motors.

Elsema's easy options to add remote controls or any type of Photoelectric Beams makes for a very user friendly approach, while avoiding the lockdown approach to accessories.

The control cards are available with an IP66 rated plastic enclosure for outdoor installations or the card only.

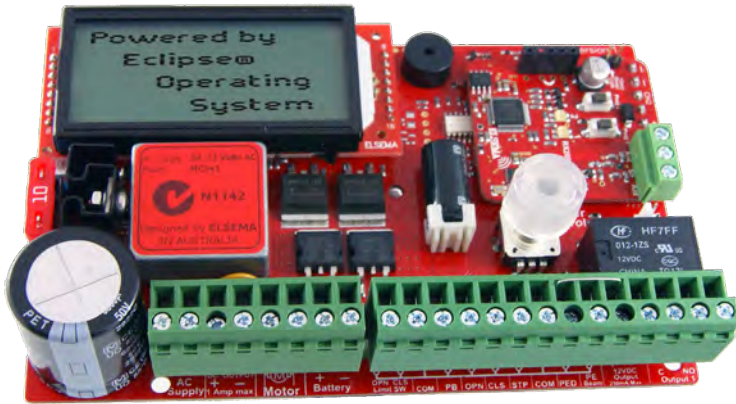

## MCS

### Part Number:

Part No.	Contents	Part No.	Contents
MCS	Single gate and door controller for 24 / 12 Volt motor up to 120 Watts	MCSv2	Single gate and door controller for 24 / 12 Volt motor bigger than 120 Watts
	For enclosed version see our MC series		
<b>Solar Gates</b>			
Solar24SP	Solar kit for double or single gates, includes solar MPPT charger & 24 Volt 15.0Ah backup battery and a 40 Watt solar panel.	Solar12	Solar kit for double or single gates, includes solar MPPT charger & 12 Volt 15.0Ah backup battery

MCS is suitable for motors up to 120 Watts. Above 120 Watts use MCSv2.

MCS & MCSv2 control card can be used to control automatic gates, doors, boom gates and automated windows or louvres.

# Menu Structure

Press Master Control for 2 seconds to enter the menu structure

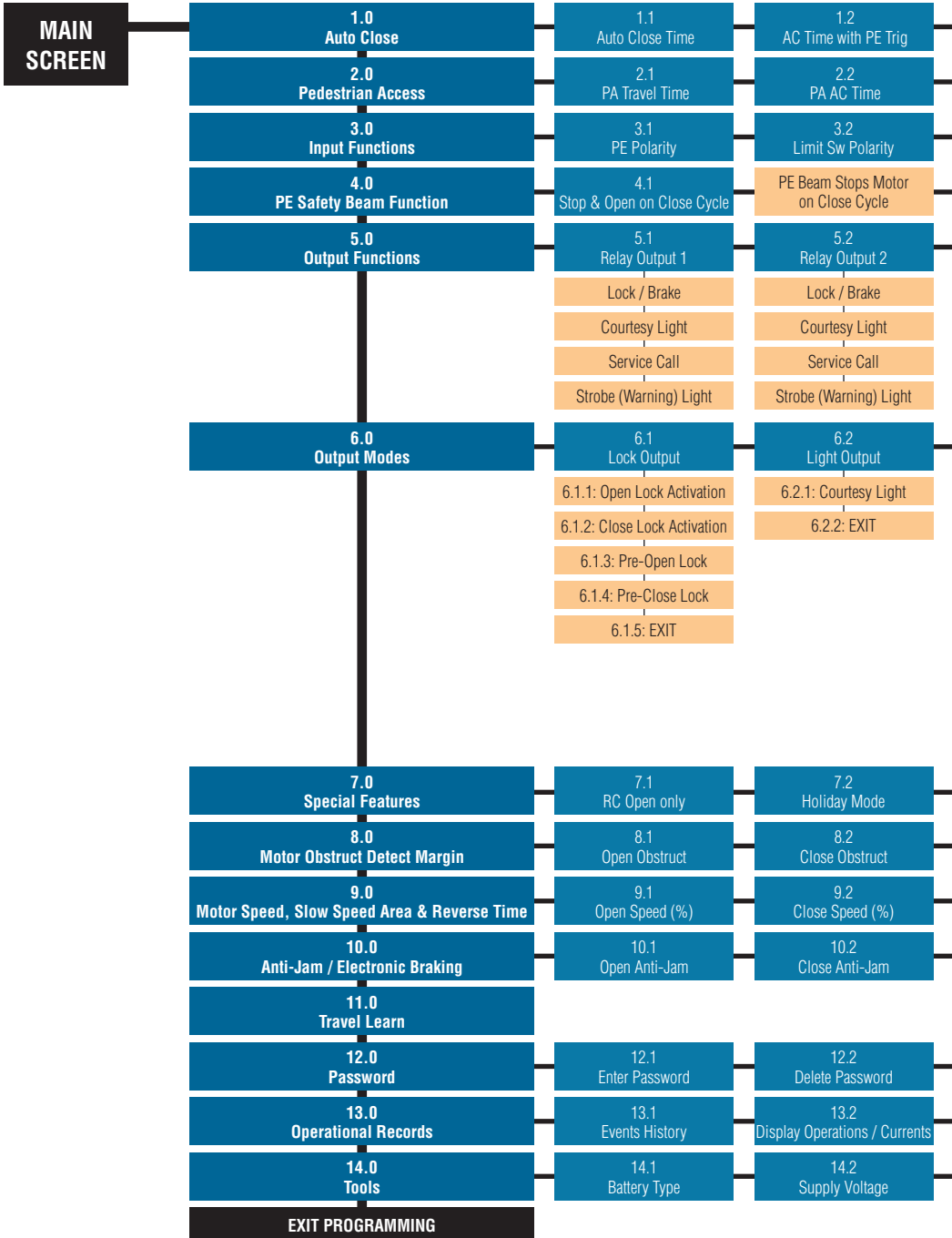

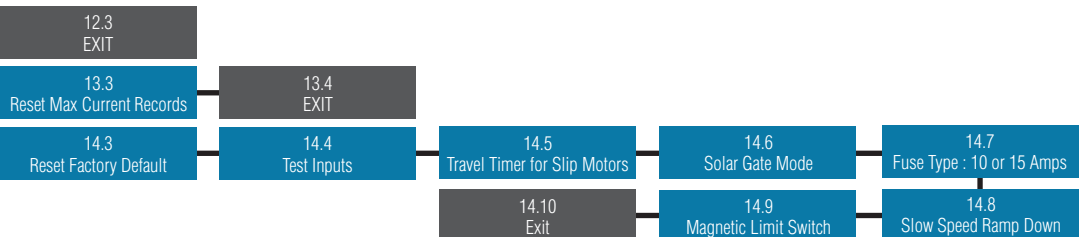
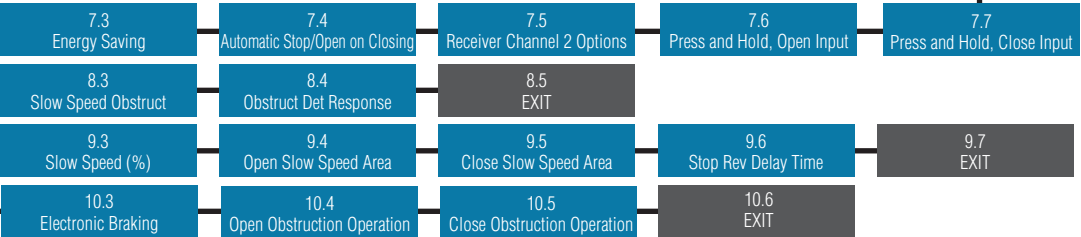
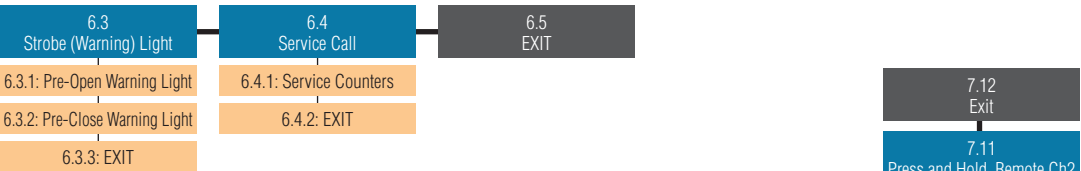
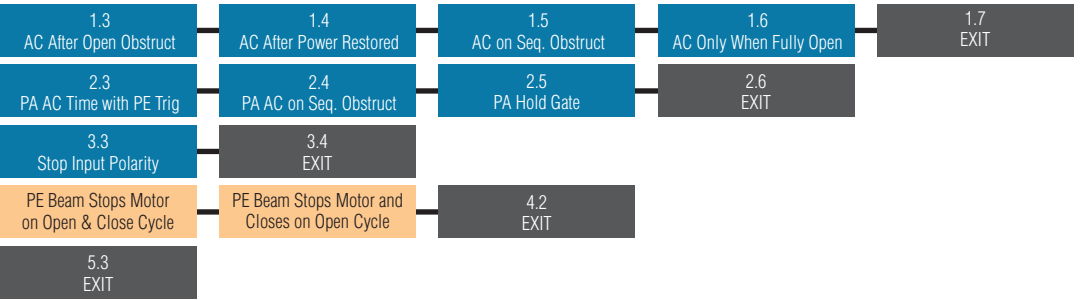

# MCS Connection Diagram

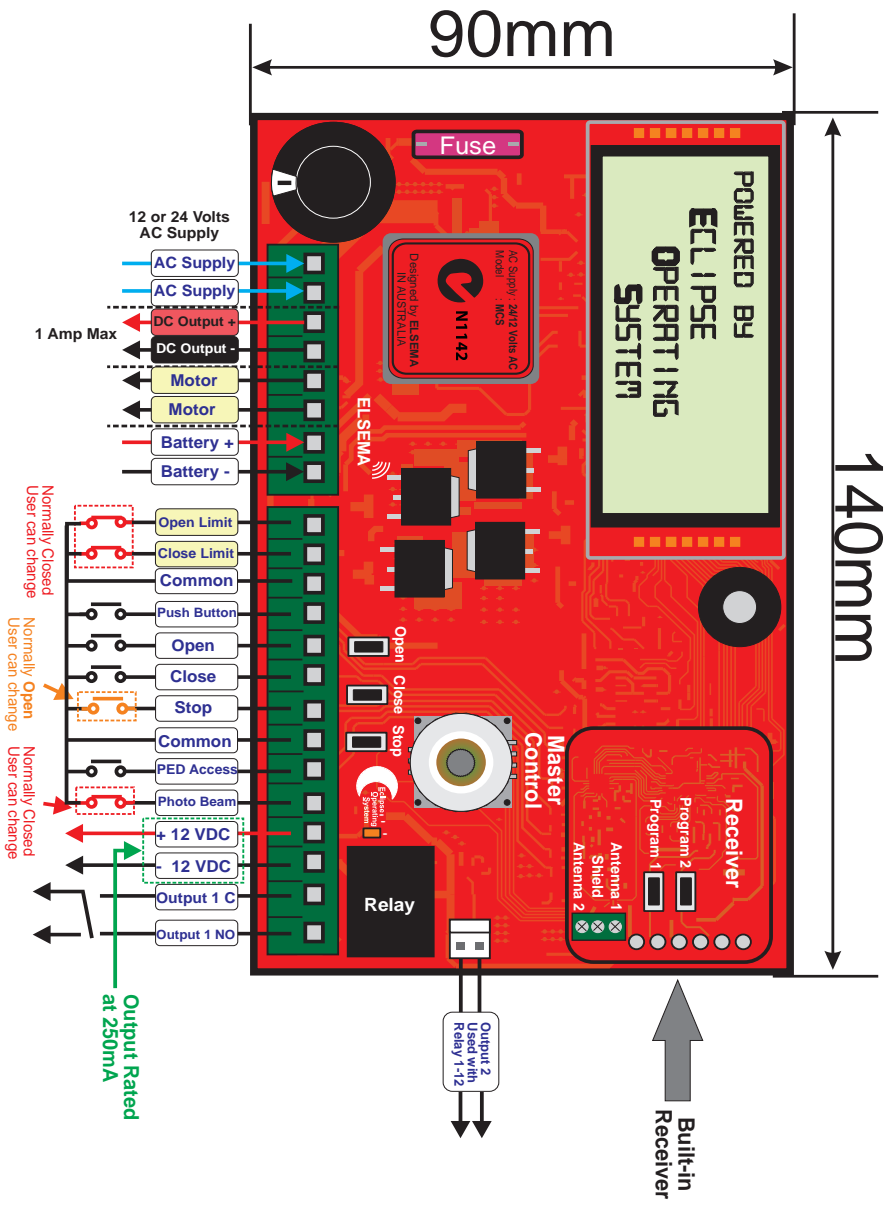



# Electrical Wiring - Supply, Motors and Inputs



Always switch off power before doing any wiring.

Make sure that all the wiring is completed and that the motor is connected to the control card.

**Recommended wire strip length should be 12mm for all connections to the plug in terminal blocks.**

The diagram below shows the supply, motors, and inputs available and the factory default setting for each input.

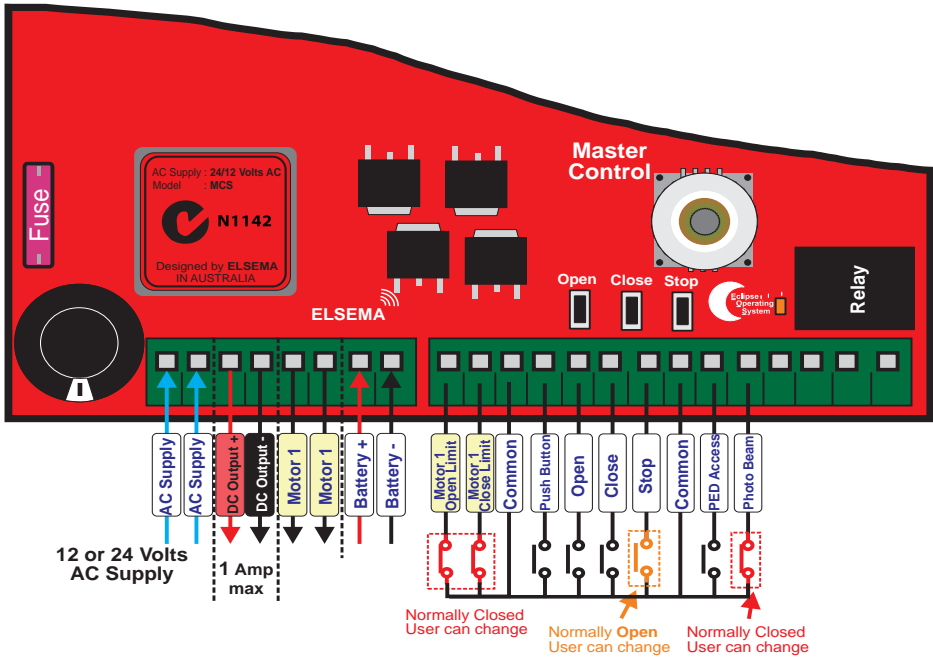

# Limit Switches

If you are using limit switches make sure they are connected properly. The control card can operate with either the limit switches connected directly to the cards terminal blocks or in series with the motor. See the diagrams below:

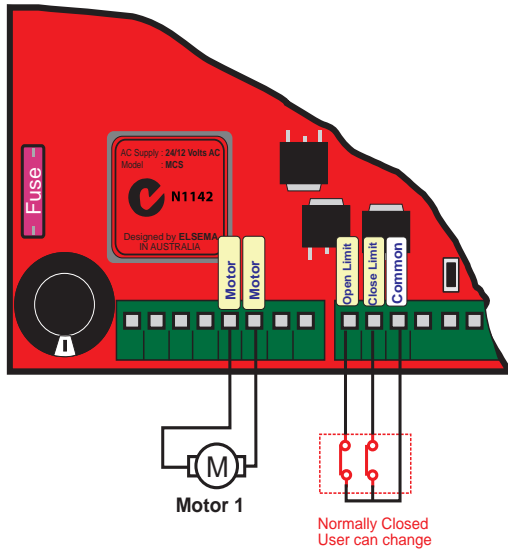

Controller with limits connected

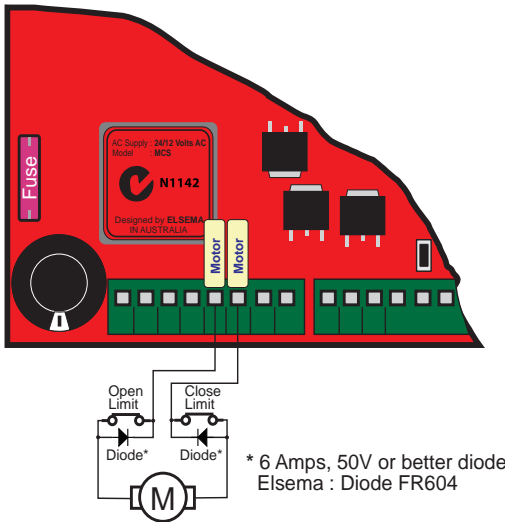

Controller with limits in series with motor

By default the limit switch inputs on the control card are normally closed (NC). This can be changed to normally open (NO) during the setup steps.

## Setup i-Learning Steps:

1. The i-Learning setup can always be interrupted with the stop button or by pressing the Master Control knob.
2. Enter Menu 11 to start i-Learning or new control cards will automatically prompt you to do the i-Learning.
3. Look at the LCD and follow the instructions displayed.
4. Buzzer will indicate learning was successful. If there was no buzzer check all electrical wiring including the power supply then go back to step 1.
5. If you hear the buzzer after the i-Learn, the gate or door is ready for use.

# Menu 1 – Auto Close

Auto Close is a feature that automatically closes the gate after a preset time has counted down to zero. The control card has a normal Auto Close and several special Auto Close features each one having its own countdown timers.

Elsema Pty Ltd recommends a Photoelectric Beam to be connected to the control card when any of the Auto Close options are used.

If the Stop input is activated Auto Close is disabled for that cycle only.

Auto Close timer will not count down if the Push Button, Open or Photoelectric Beam input is held active.

Menu No.	Auto Close Features	Factory Default	Adjustable
1.1	Normal Auto Close	Off	1 - 600 seconds
1.2	Auto Close with Photoelectric Trigger	Off	1 - 60 seconds
1.3	Auto Close after an Open Obstruction	Off	1 - 60 seconds
1.4	Auto Close after Power Restored	Off	1 - 60 seconds
1.5	Normal Auto Close on Sequential Obstructions	2	Min = Off, Max = 5
1.6	Auto Close Only when Fully Opened	Off	Off/On
1.7	Exit		

## 1.1 Normal Auto Close

The gate will close after this timer has counted down to zero.

## 1.2 Auto Close with Photoelectric Trigger

This Auto Close starts counting down as soon as the Photoelectric Beam has been cleared after a trigger even if the gate is not fully open. If there is no Photoelectric Beam trigger the gate will not Auto Close.

## 1.3 Auto Close after an Open Obstruction

If the gate opens and hits an obstruction normally the gate will stop and remain in this position. If this feature is enabled an obstruction will start the timer count down and at zero will close the gate.

### 1.4 Auto Close after Power Restored

If the gate is open in any position and then there is a power failure, when power is reconnected the gate will close with this timer.

### 1.5 Normal Auto Close on Sequential Obstructions

If the normal Auto Close is set and the gate closes onto an object the gate will stop and reopen. This setting sets the amount of times the gate will try to Auto Close. After trying for the set limit the gate will remain open.

### 1.6 Auto Close Only when Fully Opened

The Auto Close timer will not time out unless the gate is fully open.

---

## Menu 2 – Pedestrian Access

There are several types of Pedestrian Access modes. Pedestrian Access opens the gate for a short time to allow someone to walk through the gate but does not allow access to a vehicle.

Elsema Pty Ltd recommends a Photoelectric Beam to be connected to the control card when any of the Auto Close options are used.

Menu No.	Pedestrian Access Features	Factory Default	Adjustable
2.1	Pedestrian Access Travel Time	3 seconds	3 - 20 seconds
2.2	Pedestrian Access Auto Close Time	Off	1 - 60 seconds
2.3	Pedestrian Access Auto Close Time with PE trigger	Off	1 - 60 seconds
2.4	Pedestrian Access Auto Close on Sequential Obstructions	2	Min = Off, Max = 5
2.5	Pedestrian Access with Hold Gate	Off	Off/On
2.6	Exit		

## 2.1 Pedestrian Access Travel Time

This sets the time the gate opens when a Pedestrian Access input is activated.

## 2.2 Pedestrian Access Auto Close Time

This sets the countdown timer for automatically closing the gate when a Pedestrian Access input is activated.

## 2.3 Pedestrian Access Auto Close Time with PE Trigger

This Auto Close starts counting down as soon as the Photoelectric Beam has been cleared after a trigger, when the gate is in the Pedestrian Access position. If there is no Photoelectric Beam trigger the gate will remain in Pedestrian Access position.

## 2.4 Pedestrian Access Auto Close on Sequential Obstructions

If the Pedestrian Access Auto Close is set and the gate closes onto an object the gate will stop and reopen. This setting sets the amount of times the gate will try to Auto Close. After trying for the set limit the gate will remain open. When turned OFF, the gate will always try to Auto Close.

## 2.5 Pedestrian Access with Hold Gate

If the Pedestrian Access hold gate is ON and the Pedestrian Access input is permanently activated the gate will remain open in the Pedestrian Access position. Open input, Close input, Push Button input and remote controls are disable. Used in Fire Exit applications.

---

# Menu 3 – Input Functions

This allows you to change the polarity of Photoelectric Beam, Limit Switch and Stop inputs.

Menu No.	Input Functions	Factory Default	Adjustable
3.1	Photoelectric Beam Polarity	Normally Closed	Normally Closed / Normally Open
3.2	Limit Switch Polarity	Normally Closed	Normally Closed / Normally Open
3.3	Stop Input Polarity	Normally Open	Normally Closed / Normally Open
3.4	Exit		

# Menu 4 – Photoelectric Beam

The Photoelectric Beam or sensor is a safety device which is placed across the gate and when the beam is obstructed it stops a moving gate. The operation after the gate stops can be selected in this menu.

Menu No.	Photoelectric Beam Feature	Factory Default	Adjustable
4.1	Photoelectric Beam	PE Beam stops and opens gate on close cycle	PE Beam stops and opens gate on close cycle ----- PE Beam stops gate on close cycle ----- PE Beam stops gate on open & close cycle ----- PE Beam stops and closes gate on open cycle
4.2	Exit		

The factory default for the PE beam input is “normally closed” but this can be changed to normally open in Menu 3.1.

Elsema Pty Ltd recommends a Photoelectric Beam to be connected to the control card when any of the Auto Close options are used.

Elsema sells different types of Photoelectric Beams. We stock Retro-Reflective and Through Beam type Photoelectric Beams.



**PE1500**  
(Polarised Retro-Reflective Type)



**PE24**  
(Through-Beam type)

# Menu 5 – Output Functions

The control card has two outputs, Output 1 and Output 2. The user can change the function of these outputs to lock / brake, courtesy light, service call, strobe (Warning) light or gate open (gate not fully closed) indicator.

Output 1 is a relay output with common and normally open contacts. Factory default is lock / brake release function.

Output 2 is an open collector output. Factory default is courtesy light function.

Menu No.	Output Function	Factory Default	Adjustable
5.1	Output 1	Lock / Brake	Lock / Brake ----- Courtesy Light ----- Service Call ----- Strobe (Warning) Light ----- Gate Open
5.2	Output 2	Courtesy Light	Lock / Brake ----- Courtesy Light ----- Service Call ----- Strobe (Warning) Light ----- Gate Open
5.3	Exit		



## Lock / Brake Output

The factory default for output 1 is lock/ brake release. Output 1 is a voltage-free relay contact with common and normally open contacts. Having it voltage-free allows you to connect either 12VDC/AC, 24VDC/AC or 240VAC to the common. The normally open contact powers the device. See diagram below:

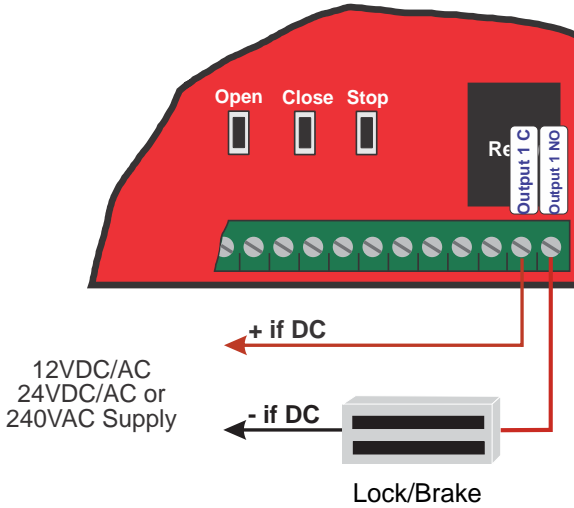

---

## Courtesy Light

The factory default for the courtesy light is on output 2. Output 2 is an open collector output. This output is used to switch an external relay such as Elsema's REL12-1 which can be purchased separately. See diagram on the next page.

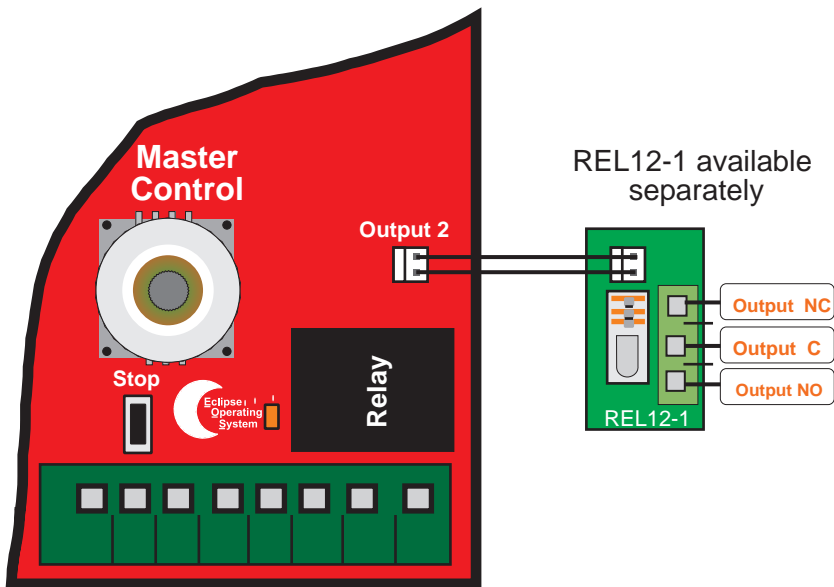

---

## Service Call Output

Either output 1 or output 2 can be changed to service call indicator. This will trigger the output when the software service counter is reached. Used to alert installers or owners when the gate is to be serviced. Using Elsema's GSM receiver allows installers or owners to get a SMS message and a call when the service is due.

---

## Strobe (Warning) Light when Opening or Closing

The relay output is activated whenever the gate is operating. The factory default is Off. Either output 1 or output 2 can be changed to strobe (Warning) light.

---

## Gate Open

The relay output is activated whenever the gate is not fully closed. The factory default is Off. Either output 1 or output 2 can be changed to gate open.

# Menu 6 – Relay Output Modes

## Menu 6.1 – Lock / Brake Output Modes

The relay output in the lock / brake mode can be configured in different ways.

Menu No.	Lock / Brake Modes	Factory Default	Adjustable
6.1.1	Open Lock / Brake Activation	2 seconds	1 – 30 seconds or hold
6.1.2	Close Lock / Brake Activation	Off	1 – 30 seconds or hold
6.1.3	Open Pre-Lock / Brake Activation	Off	1 – 30 seconds
6.1.4	Close Pre-Lock / Brake Activation	Off	1 – 30 seconds
6.1.5	Exit		

### 6.1.1 Open Lock / Brake Activation

This sets the time the output is activated in the open direction. Factory default is 2 seconds. Setting it to Hold means the output is activated for the total travel time in the open direction.

### 6.1.2 Close Lock / Brake Activation

This sets the time the output is activated in the close direction. Factory default is off. Setting it to Hold means the output is activated for the total travel time in the close direction.

### 6.1.3 Open Pre-Lock / Brake Activation

This sets the time the output is activated before the motor starts in the open direction. Factory default is Off.

### 6.1.4 Close Pre-Lock / Brake Activation

This sets the time the output is activated before the motor starts in the close direction. Factory default is Off.

# Menu 6.2 – Courtesy Light Output Mode

The relay output in the courtesy mode can be adjusted from 30 to 300 seconds. This sets the time the courtesy light is activated. Factory default is 60 seconds.

Menu No.	Courtesy Light Mode	Factory Default	Adjustable
6.2.1	Courtesy Light Activation	60 seconds	30-300 seconds
6.2.2	Exit		

---

# Menu 6.3 – Strobe (Warning) Light Output Mode

The relay output in the strobe (Warning) mode can be configured in different ways:

Menu No.	Strobe (Warning) Light Mode	Factory Default	Adjustable
6.3.1	Pre-Open Strobe (Warning) Light Activation	Off	1 – 30 seconds
6.3.2	Pre-Close Strobe (Warning) Light Activation	Off	1 – 30 seconds
6.3.3	Exit		

## 6.3.1 Pre-Open Strobe Light Activation

This sets the time the strobe light is activated before the gate operates in the open direction. Factory default is Off.

## 6.3.2 Pre-Close Strobe Light Activation

This sets the time the strobe light is activated before the gate operates in the close direction. Factory default is Off.

# Menu 6.4 – Service Call Output Mode

This sets the number of complete cycles (Open and Close) required before the built-in buzzer is activated. Also the control card outputs can be configured to be activated if the number of cycles is completed. Connecting Elsema's GSM receiver to the output allows owners to get a phone call & SMS message when the service is due.

When "Service Call Due" message shows up on the LCD a service call is required. After service has been done, follow the messages on the LCD.

Menu No.	Service Call Mode	Factory Default	Adjustable
6.4.1	Service Counter	Off	Min: 2000 to Max: 50,000
6.4.2	Exit		

# Menu 7 – Special Features

The control card has many special features that can all be customised to your specific application.

Menu No.	Special Features	Factory Default	Adjustable
7.1	Remote Control Open Only	Off	Off / On
7.2	Holiday Mode	Off	Off / On
7.3	Energy Saving Mode	Off	Off / On
7.4	Automatic Stop & Open on Closing	On	Off / On
7.5	Receiver Channel 2 Options	Off	Off / Light / Pedestrian Access / Close Only
7.6	Press and Hold for Open Input	Off	Off / On
7.7	Press and Hold for Close Input	Off	Off / On
7.8	Window / Louvre	Off	Off / On
7.9	Reserved	Off	Off / Low / medium / High
7.10	Press & Hold Remote Channel 1 (Open)	Off	Off / On
7.11	Press & Hold Remote Channel 2 (Close)	Off	Off / On
7.12	Exit		

## 7.1 Remote Control Open Only

By default the remote control allows the user to open and close the gate. In public access areas user should only be able to open the gate and not worry about closing it. Usually the Auto Close is used to close the gate. This mode disables closing for the remote controls.

## 7.2 Holiday Mode

This feature disables all the remote controls.

## 7.3 Energy Saving Mode

This puts the control card to very low standby current that reduces your electricity bill while still maintaining normal functions and operations.

## 7.4 Automatic Stop & Open on Closing

By default when the gate is closing and a push button or remote control is activated it will automatically stop and open the gate. When this feature is disabled, the gate will only stop. Automatic opening will be disabled.

## 7.5 Receiver Channel 2 Options

The receivers 2nd channel can be programmed to control a courtesy light, pedestrian access or can be used for close only.

## 7.6 & 7.7 Press and Hold for Open and Close Inputs

If this feature is ON the user must continuously press the open or close input for it to be activated.

## 7.8 Window or Louvre Mode

This mode optimises the control card for operating electronic windows or louvres.

## 7.10 & 7.11 Press and Hold for Remote Channel 1 (Open) and Channel 2 (Close)

The remote channel 1 & 2 buttons will need to be programmed to receiver channel 1 & 2. The user must continuously press the remote button for the gate to open or close. The gates will stop as soon as the buttons are released.

---

# Menu 8 – Obstruction Detect Margins

This sets the current sensitivity margin above the normal run current to trip the gate if an obstruction is detected. Different obstruction margins and response time can be set for the open and close direction.

The minimum margin will allow least pressure applied to trip the gate if it hits an object. The maximum margin will allow for a large amount of pressure applied to trip the gate if it hits an object.

Menu No.	Obstruction Detect Margins and Response Time	Factory Default	Adjustable
8.1	Open Obstruction Margin	1 Amp	0.2 - 6.0 Amps
8.2	Close Obstruction Margin	1 Amp	0.2 - 6.0 Amps
8.3	Open and Close Slow Speed Obstruction Margin	1 Amp	0.2 - 6.0 Amps
8.4	Obstruction Detect Response Time	Medium	Fast, Medium, Slow and Very Slow
8.5	Exit		

## Margin Example

Motor is running at 2 Amps and the margin is set to 1.5 Amps, an obstruction detect will occur at 3.5 Amps (Normal Running Current + Margin).

For high margin settings, the supply transformer should be large enough to supply the high margin current.

If the gate hits an object on closing it will automatically stop and then re-open. If the gate hits an object on opening it will automatically stop.

# Menu 9 – Motor Speed, Slow Speed Area and Reverse Time

Menu No.	Motor Speed, Slow Speed Area and Reverse Time	Factory Default	Adjustable
9.1	Open Speed	80%	50% to 125%
9.2	Close Speed	70%	50% to 125%
9.3	Open and Close Slow Speed	50%	25% to 65%
9.4	Open Slow Speed Area	4	1 to 12
9.5	Close Slow Speed Area	5	1 to 12
9.6	Stop Reverse Delay	0.4 seconds	0.2 to 2.5 seconds
9.7	Exit		

After changing open speed, close speed or slow speed, i-Learn has to be done again.

## 9.1 & 9.2 Open and Close Speed

This sets the speed at which the gate will travel. If the gate is travelling too fast reduce this value.

## 9.3 Slow Speed

This sets the speed at which the gate will travel in the slow speed region. If the gate is travelling too slow increase this value.

## 9.4 & 9.5 Slow Speed Area

This sets the slow speed travel area. If you want more travel time for the slow speed area increase this value.

## 9.6 Obstruction Stop Reverse Delay Time

This sets the stop and reverse delay time when the gate hits an obstruction.



# Menu 10 – Anti-Jam, Electronic Braking and Gate Movement after Obstruction

Menu No.	Anti-Jam or Electronic Braking	Factory Default	Adjustable
10.1	Open Anti-Jam	OFF	0.1 to 2.0 seconds
10.2	Close Anti-Jam	OFF	0.1 to 2.0 seconds
10.3	Electronic Braking	OFF	Off/On
10.4	Gate Movement after Obstruction in Opening Direction	Stop	Stop / Reverse for 2 sec / Reverse Fully
10.5	Gate Movement after Obstruction in Closing Direction	Reverse for 2 seconds	Stop / Reverse for 2 sec / Reverse Fully
10.6	Exit		

## 10.1 and 10.2 Motor Open and Close Anti-Jam

When the gate are in the fully open or fully closed position this feature applies a reverse voltage for a very short time. It will prevent the motor from jamming up the gate so it is easy to disengage the motors for manual operation.

## 10.3 Electronic Braking

This will stop the motors with an electronic brake. Brake is applied when an obstruction is detected or when the Stop input is triggered.

## 10.4 Opening Direction : Gate Movement after Obstruction

After an obstruction has occurred in the opening direction, the gate will either stop, reverse for 2 seconds or reverse fully.

## 10.5 Closing Direction : Gate Movement after Obstruction

After an obstruction has occurred in the close direction, the gate will either stop, reverse for 2 seconds or reverse fully.

# Menu 11 – i-Learning

This feature allows you to do the intelligent travel learning of the gate. Follow the messages on the LCD to complete the learning.

---

# Menu 12 – Password

This will allow the user to enter a password to prevent unauthorised users from entering the control card settings. User must remember the password. The only way to reset a lost password is to send the control card back to Elsema.

To delete a password select Menu 12.2 and press Master Control.

---

# Menu 13 – Operational Records

This is for information only.

Menu No.	Operational Records
13.1	Event History, up to 100 events are recorded in the memory
13.2	Displays Gate Operations and Currents Levels
13.3	Reset Maximum Current Records
13.4	Exit

## 13.1 Event History

The event history will store 100 events. The following events are recorded into the memory: Power On, Low Battery, All input activations, Successful Opening, Successful Closing, Obstruction Detected, Unsuccessful i-Learning Attempt, Factory Reset, DC Output Overloaded, AC Supply Failed, AC Supply Restored, Auto Close, Security Close and Fuse Protect Obstruction.

## 13.2 Displays Gate Operations and Current Levels

This displays the number of open cycles, close cycles, pedestrian cycles, open obstructions, close obstructions and motor current levels. All maximum current values can be reset by the user from Menu 13.3.

# Menu 14 – Tools

Menu No.	Tools
14.1	Battery Type : Lithium-ion or Lead Acid battery
14.2	Set the Supply Voltage : 12 or 24 Volts
14.3	Resets Controller to Factory Settings
14.4	Test Inputs
14.5	Travel Timer for Slip Clutch Motors
14.6	Solar Gate Mode : Optimises the Control Card for Solar Applications
14.7	Fuse Type : 10 or 15 Amps Optimises the Control Card for the correct Blade Fuse used
14.8	Slow Speed Ramp Down Time
14.9	Magnetic Limit Switch
14.10	Exit

## 14.1 Battery Type

The MCS can be used with 2 types of backup batteries, Lead Acid & Lithium-ion. **Default setting is Lead Acid. Never connect a lithium battery when lead acid mode is selected. Always select the correct battery type.** Only use Lithium-ion batteries supplied by Elsema.

## 14.2 Set the Supply Voltage

The control card automatically sets the supply voltage during setup. This option allows you to manually set the control card to 12 or 24 Volt supply. To use the control card in a solar application you must set the correct voltage in the Tools. This will disable the automatic voltage sensing which could cause problems in solar applications.

## 14.3 Resets Controller

Reset all settings to factory default. Also removes password.

## 14.4 Test Inputs

This allows you to test all the external devices connected to the controllers inputs. UPPERCASE means input is activated and lowercase means input is activated.

## 14.5 Travel Timer for Slip Clutch Motors

This allows you to use the controller with travel time. Used for Slip clutch or Hydraulic Motors

## 14.8 Slow Speed Ramp Down Time

This allows you to change the time it takes the gate to change its speed from fast to slow.

## 14.9 Magnetic Limit Switch

Only enable this option when using Elsema's magnetic Limit Switch.

# Accessories

## Backup Batteries & Battery Charger

The control card has a built in charger for backup batteries. Simply connect the batteries to the battery terminal and the charger will automatically charge the batteries. Elsema has a range of battery sizes.



Backup Batteries

## Solar Applications

Elsema stocks solar gate controller kits, solar panels, solar chargers and full solar gate operators as well.

### **WARNING**

To use the control card in a solar application you must set the correct voltage input in the Tools Menu (16.2). This will disable the automatic voltage sensing which could causes problems in solar applications.



Solar Panels

## Pre-made Inductive Loops & Loop Detectors

Elsema has a range of Saw-Cut and Direct Burial loops. They are pre-formed with recommended loop sizes for commercial or domestic applications and makes installation quick and easy.



Inductive Loop



Loop Detectors

## Wireless Bump Strip

Safety edge bump strip is installed on the moving gate or barrier along with the transmitter. When the gate hits an obstacle, the transmitter transmits a wireless signal to the receiver to stop the gate from causing further damage.



Safety Bump Strip

## Keyring Remotes

The latest PentaFOB® keyring remotes ensure your gates or doors are secure. Visit [www.elsema.com](http://www.elsema.com) for more details.

### PentaFOB® Remotes



### Booster for PentaFOB® remotes

Penta Repeater can increase the operating range of the keyring remotes to up to 500 metres.

### PentaFOB® Programmer

Add, edit and delete PentaFOB® remotes from the receiver's memory. The receiver can also be password protected from unauthorised access.



PentaFOB® Programmer



Repeater/ booster for PentaFOB® remotes

### Flashing Lights

Elsema has several flashing lights to act as a warning when the gate or doors is in operation.



Flashing Lights

# PentaFOB® Programming Instructions

**Coding the PentaFOB® remotes and receivers can be done in 2 different ways.**

1. Using the Receiver
2. Using another Remote Control

## **Coding using the Receiver**

1. Press and hold the program button on the receiver
2. Press the remote button for 2 seconds, receiver LED will flash and then turn Green
3. Release the button on the receiver and the remote
4. Press remote control button to test the receiver output

## **Coding using another Remote Control (you should be near the receiver for this procedure)**

1. Open the case of a remote control that is already programmed and press and release the program button on the back of the board (The receiver enters learning mode)
2. Press the button of the remote in step 1 which activates the receiver
3. Press the button on the new remote which needs to be programmed for 2 seconds
4. Press the program button again of the remote in step 1(The receiver exits learning mode)
5. Press the new remote control button to test the receiver output

## **Deleting Receivers Memory**

Short the Code Reset pins on the receiver for 10 seconds. **This will delete all the remotes from the receiver's memory.**

## **PentaFOB® Programmer**

This programmer allows you to add and delete certain remotes from the receiver memory. This is used when a remote control is lost or a tenant moves from the premises and the owner wants to prevent un-authorized access.

## **PentaFOB® Backup Chips**

This chip is used to backup or restore the contents of a receiver. When there are 100's of remotes programmed to a receiver the installer normally backups the receiver memory in case the receiver is damaged.





Keyring remote controls



Sliding gate motor kits

**ELSEMA**  
**INTELLIGENT SLIDER**

Swinging gate motor kits

**ELSEMA**  
**INTELLIGENT SWING**



Sliding gate motor kits



Swinging gate motor kits



Motor control cards & Kits



**ELSEMA**  
GATE & DOOR CONTROLS

**ELSEMA PTY LTD**  
31 Tarlington Place  
Smithfield NSW 2164 Australia  
**P** 02 9609 4668  
**W** [www.elsema.com](http://www.elsema.com)